

The search for Light Dark Matter with DAMIC

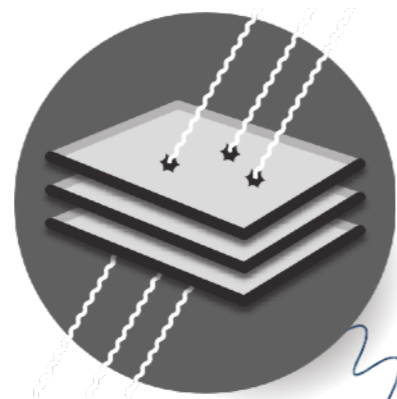

CENPA

Center for Experimental Nuclear Physics and Astrophysics

Alvaro E. Chavarria
University of Washington

Outline

- ▶ Dark matter.
- ▶ Direct detection of (light) dark matter.
- ▶ Charge-coupled devices.
- ▶ Characterized response.
- ▶ DAMIC at SNOLAB: Physics + backgrounds.
- ▶ DAMIC-M(1K) at LSM: low background 1-kg silicon detector with single-electron response.

Dark matter

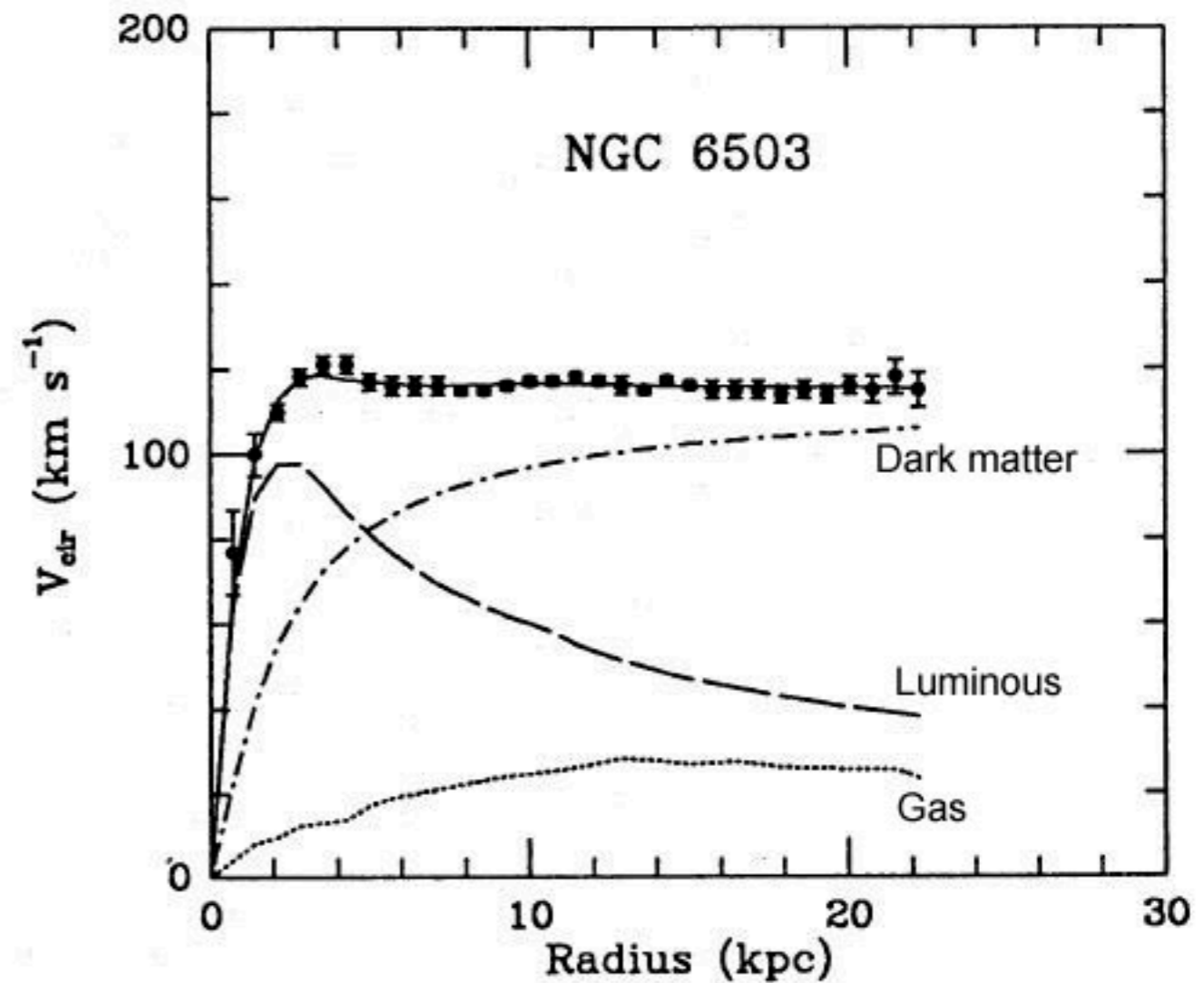
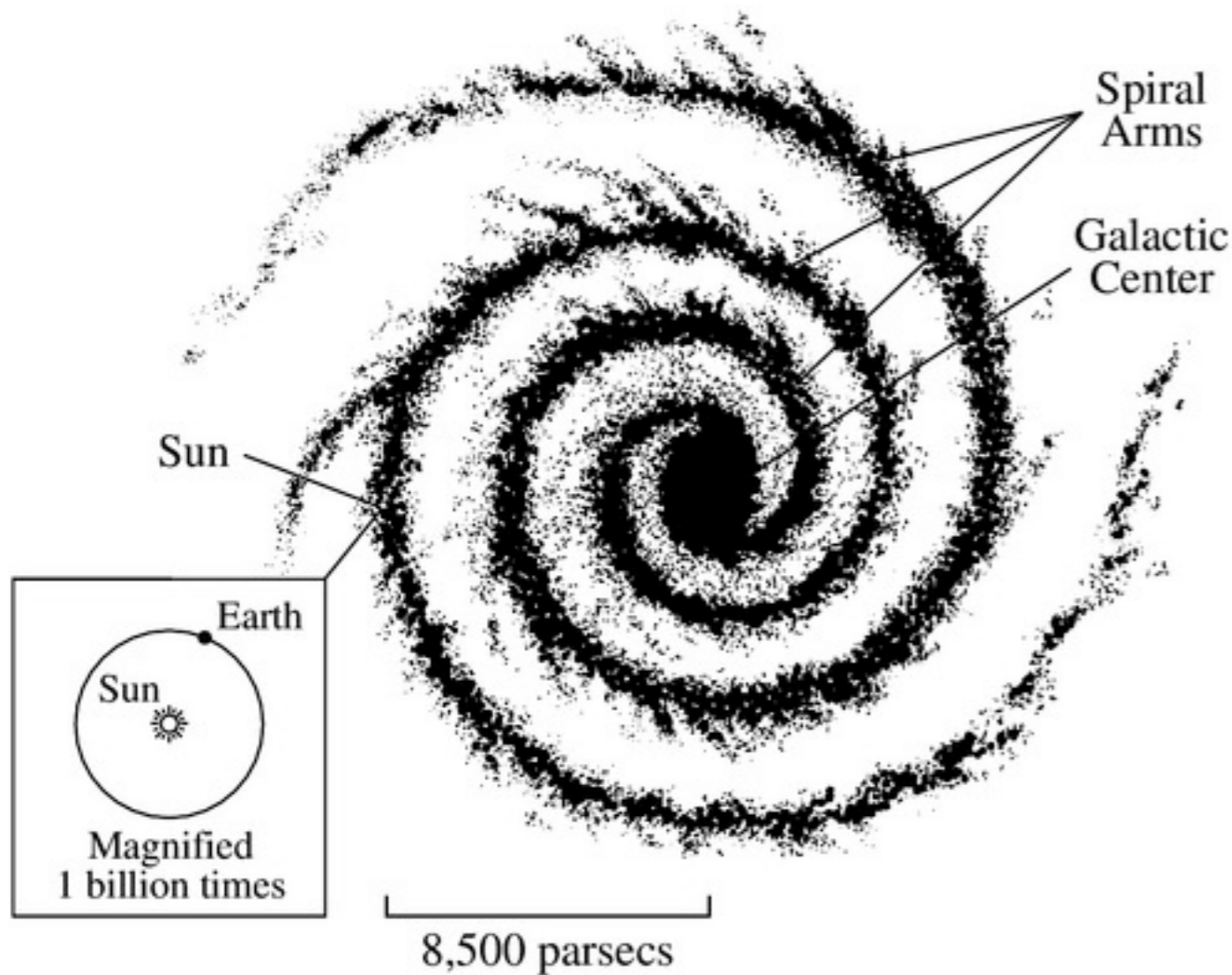

The centripetal force exerted on the “Sun” cannot be explained by stars and gas.

Evidence from cosmology, formation of galaxies and clusters of galaxies and gravitational lensing.

Relic abundance

Dark matter is a particle created in the Big Bang... maybe?

Abundance is from thermal 'freeze-out', e.g. Dark matter is a Majorana fermion: the WIMP miracle.

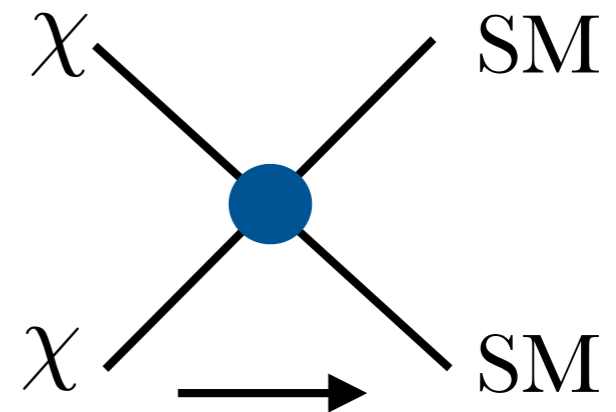

Asymmetric dark matter. Abundance arises by some asymmetry between matter and anti-matter (e.g. CP violation) in the dark sector, as for baryons.

Abundance arises from "misalignment mechanism" in the early Universe, as for bosonic dark matter, e.g. axions.

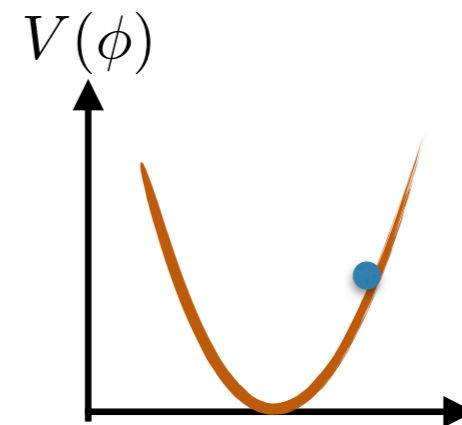

Dark matter signal

Local density is ~ 0.3
 $\text{GeV } c^2 \text{ cm}^{-3}$.

Interaction cross-section
is *small*.

Dark matter is *cold*, kinetic
energy is $10^{-6} Mc^2$.

WIMP Lab Speed Distribution

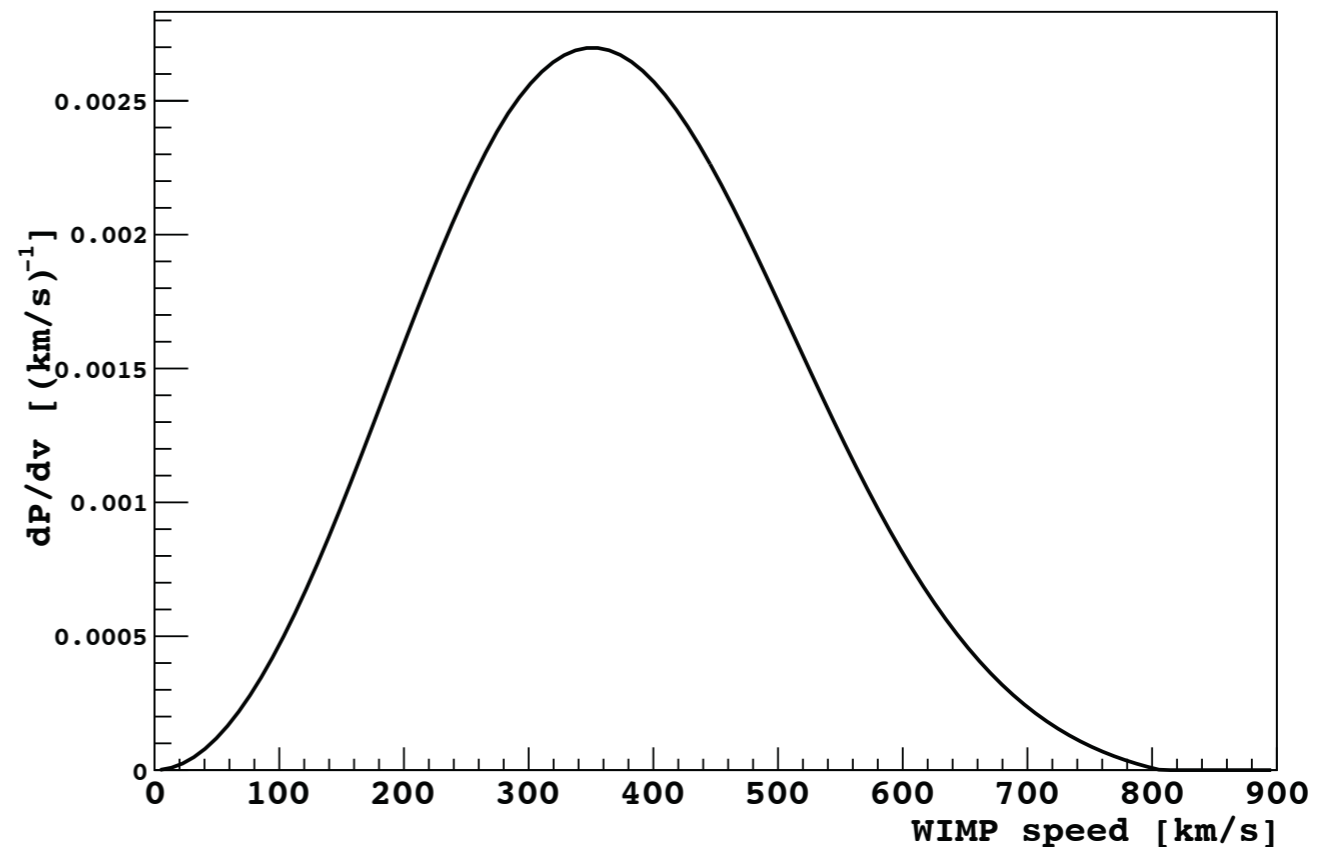

Dark matter particle can deposit at most its kinetic energy (if fermion) or its rest energy (if boson).

Need detector with **low energy threshold**, largest possible exposure and correspondingly low backgrounds.

DM-nucleus ES

Traditional mechanism for WIMP searches:

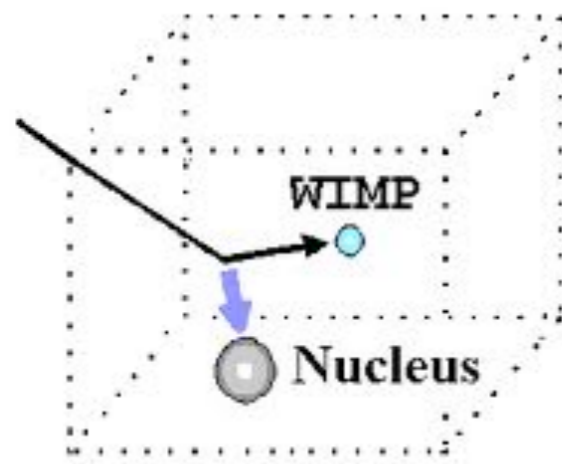

Maximum energy transfer when $M \sim A$

For low-mass WIMP:

$$M_T \gg M_\chi \quad E_T < 4 \frac{M_\chi}{M_T} E_\chi$$

Recoil spectrum in Si target

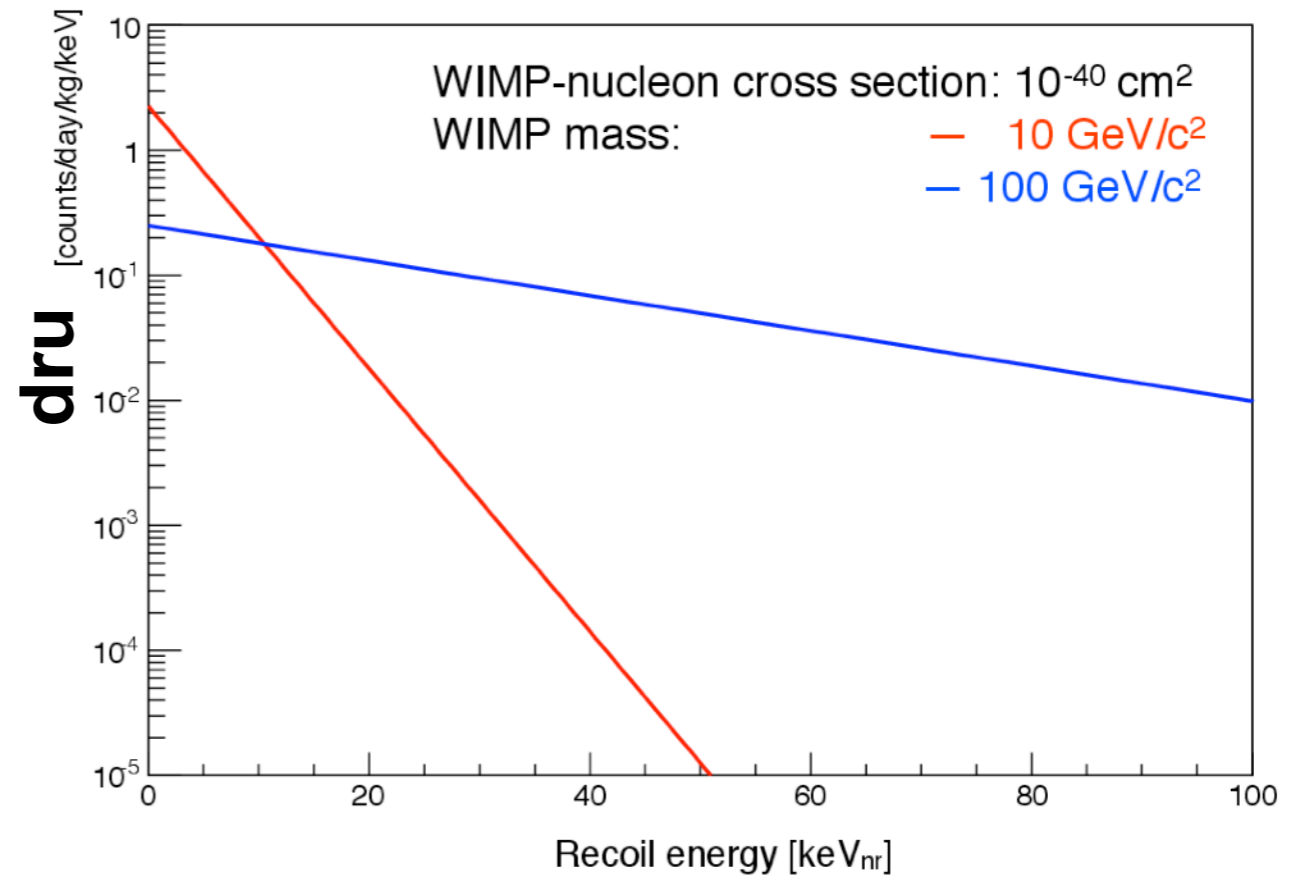

Lower recoil energies for smaller WIMP masses

Coherent enhancement:

$$\sigma_N \propto A^2$$

Lighter DM

Lighter target: lighter nucleus or *electron*

Electrons bound with some momentum, inelastic process.

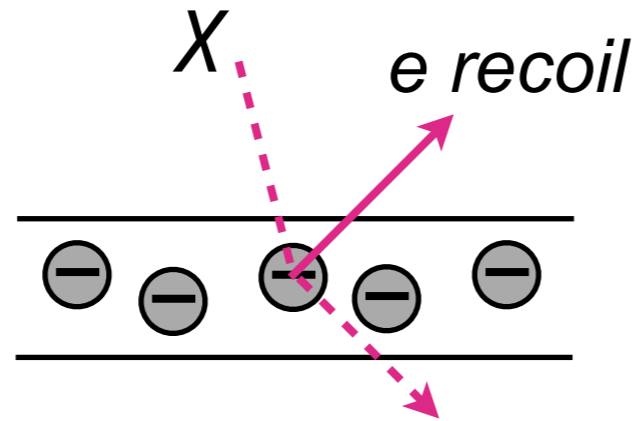

Rapid loss in sensitivity

Lower threshold, smaller band gap

Ionization energy of noble liquids ~ 10 eV

Semiconductor band gap ~ 1 eV!

Warm DM

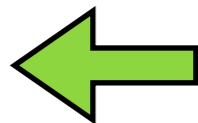

WIMP mass [GeV]

WIMP mass [GeV]

σ_n [pb]

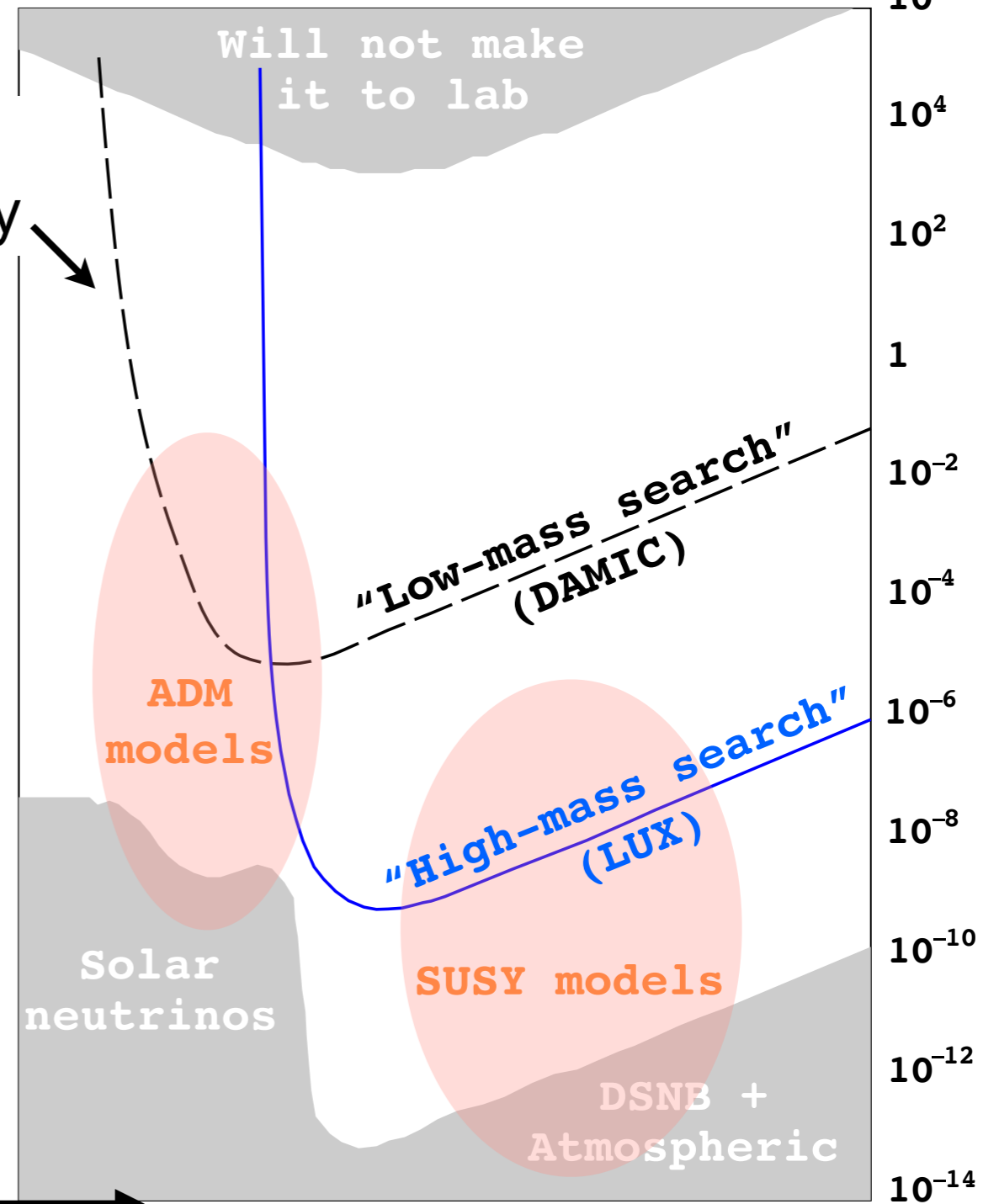

Vector-portal DM

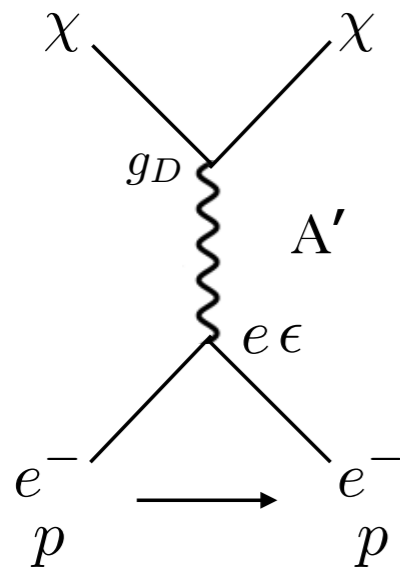

“Hidden” $U(1)$ that “talks” to ordinary matter by a kinetic mixing of A' with the EM photon.

The dark matter can be fermions or complex scalars charged under $U(1)'$, or a massive A' .

Phenomenology depends on masses of M_A and M_χ .

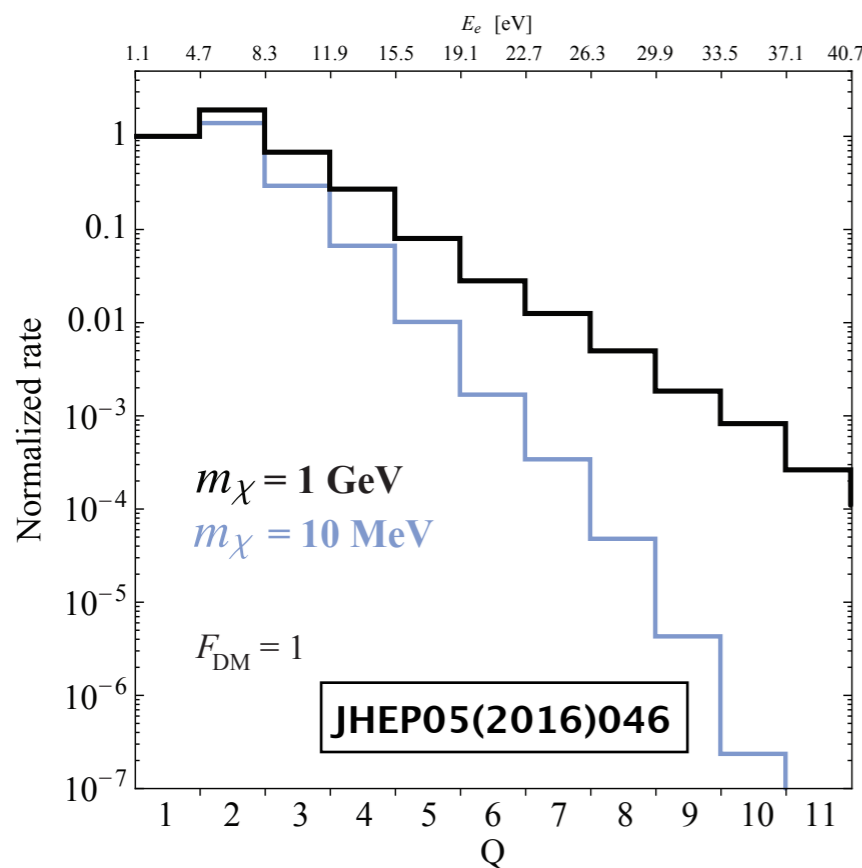

← **Direct detection** signal in silicon target from “contact” interaction, i.e., heavy M_A .

Searches at **accelerators** for electron’s missing momentum (**LDMX**) or χ interacting directly (**BDX**):

E.g., $M_A > 2M_\chi$

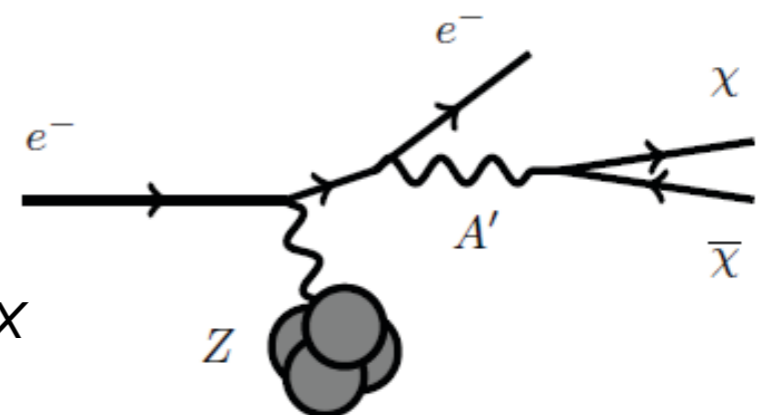

Charge coupled device

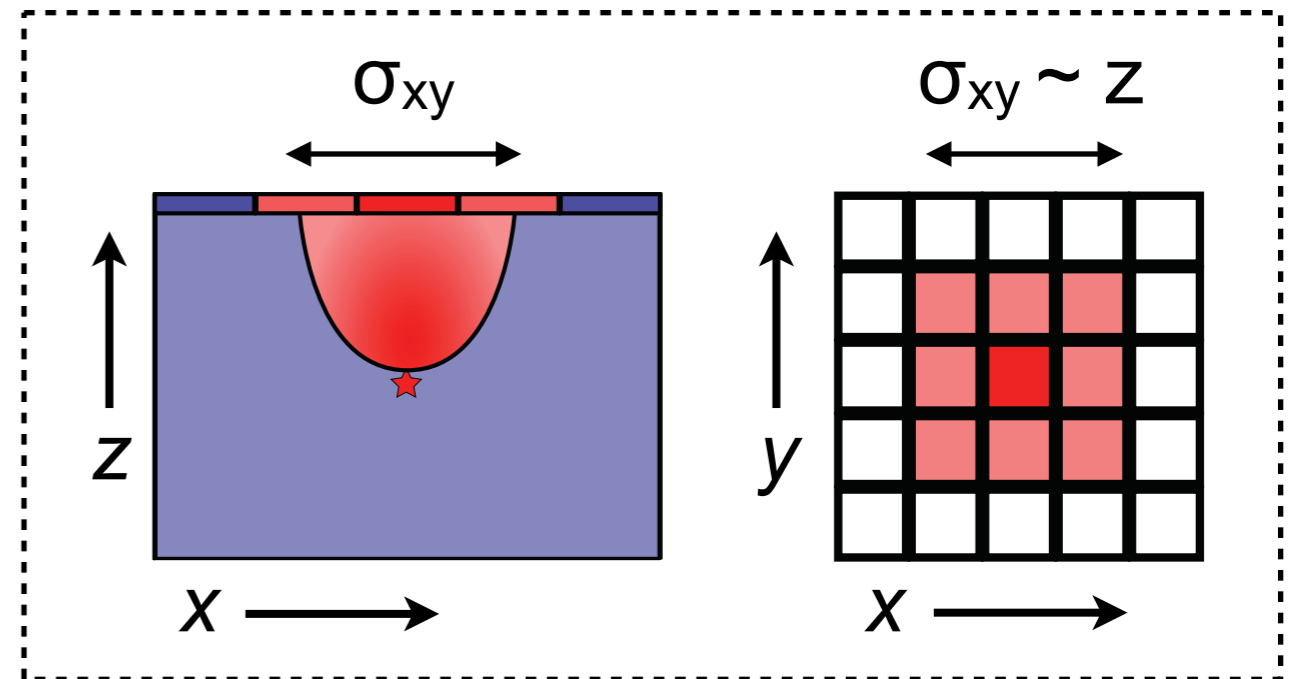
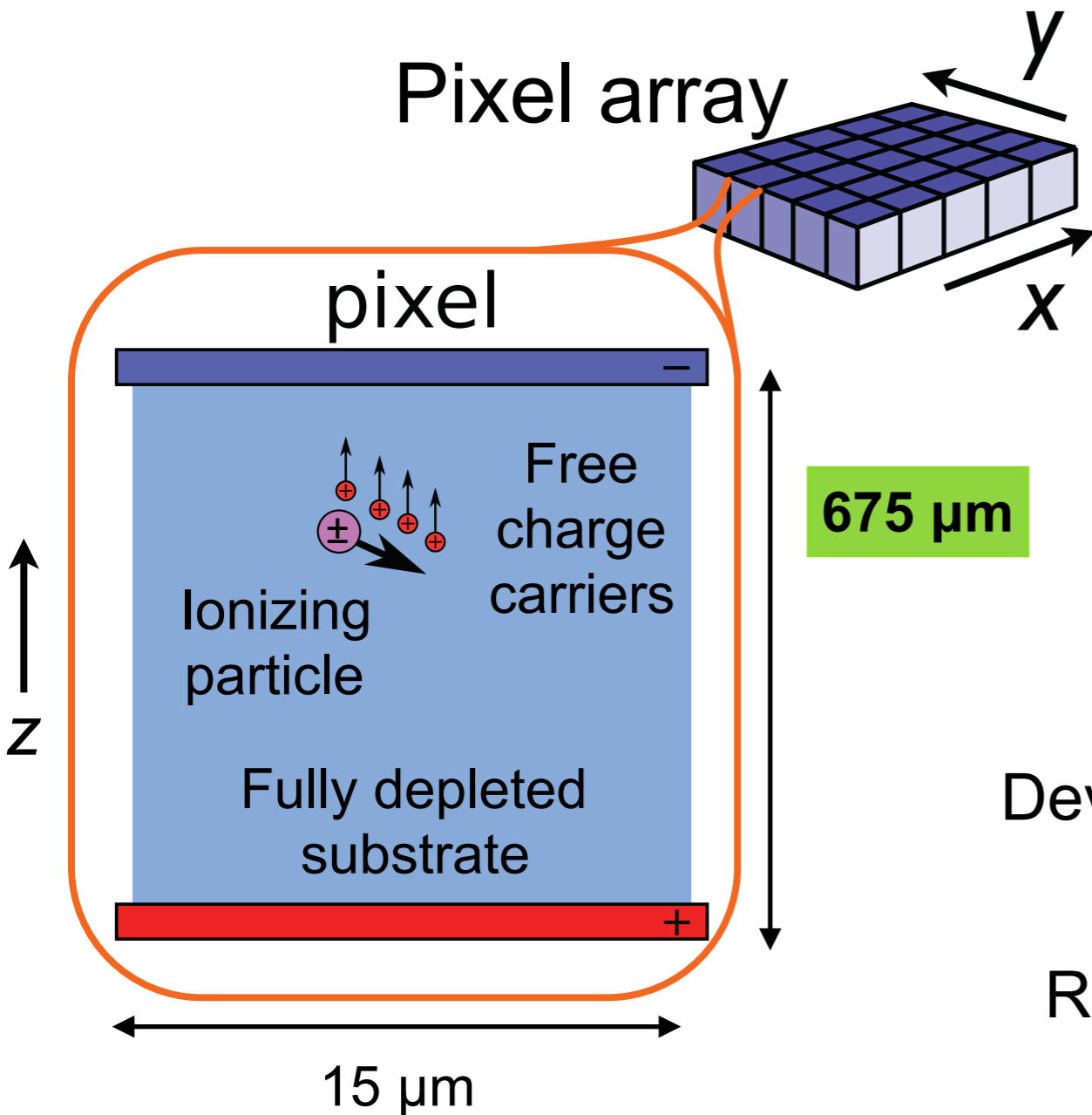

Device is “exposed,” collecting charge until user commands readout

Readout can be slow / non-destructive :
very low noise (few e⁻)

Standard fabrication in semiconductor industry and easy cryogenics (~100 K).

Silicon band-gap: 1.2 eV
Mean energy for 1 e-h pair: 3.8 eV

Performance

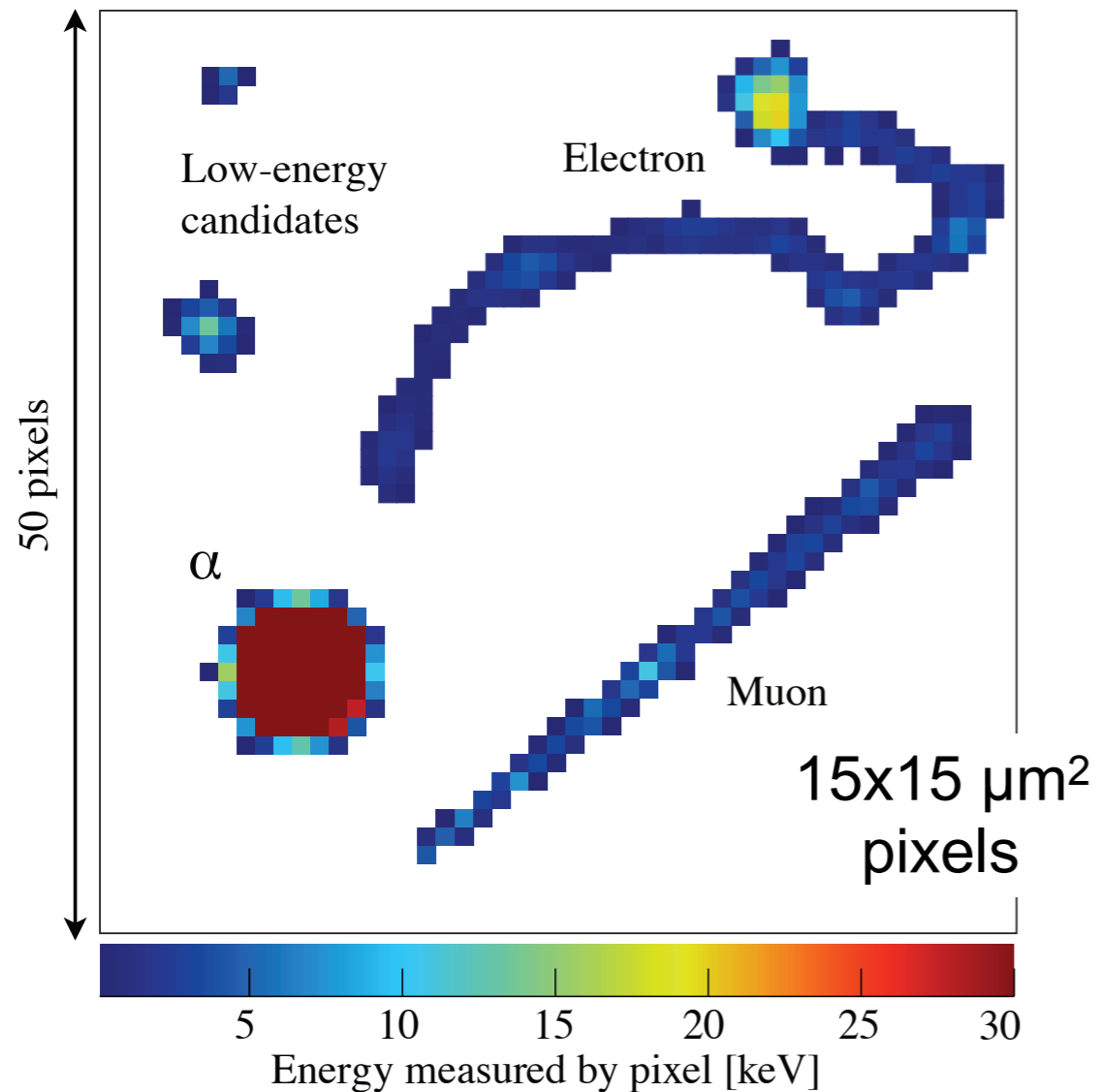

Pixel charge distribution

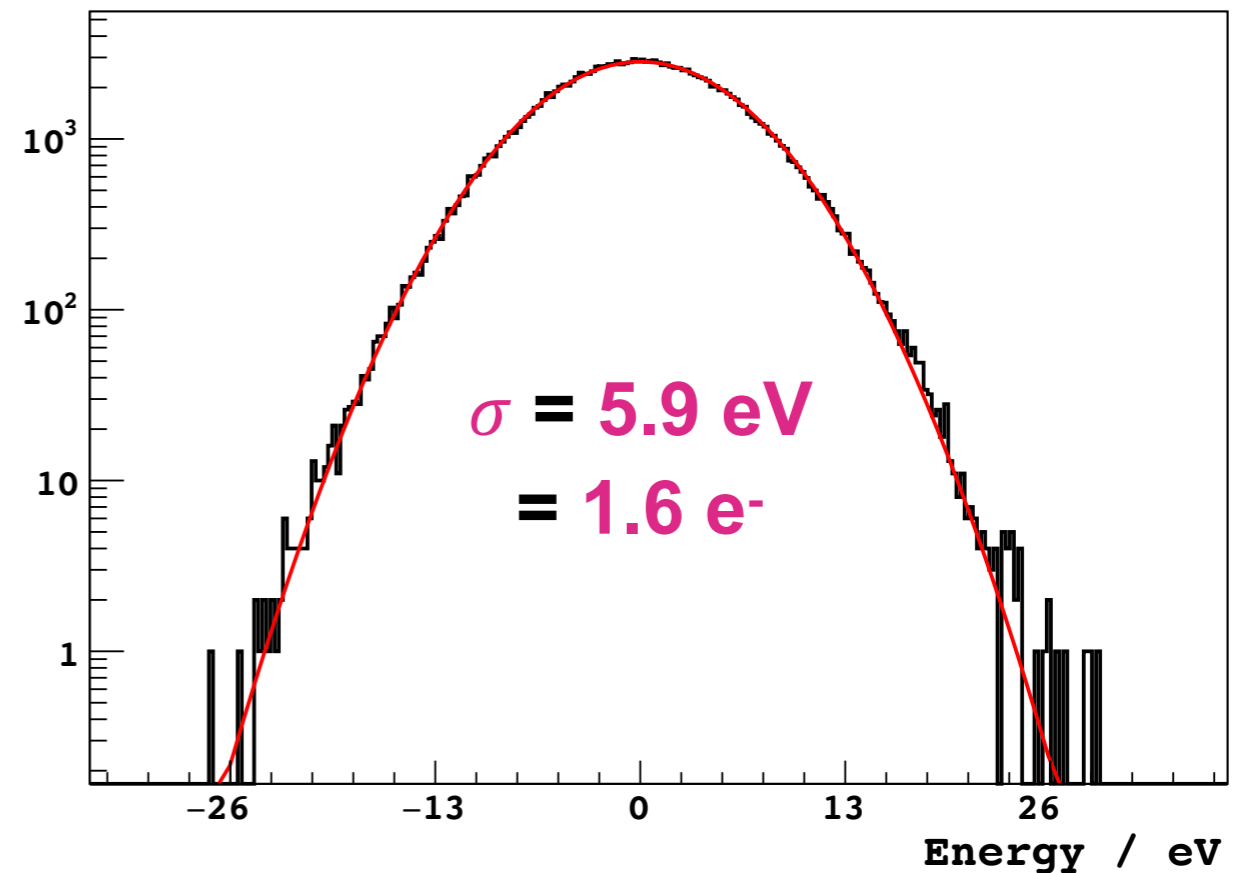

Very low noise and dark current

lowest dark current ever measured
in a silicon detector:
 $5 \times 10^{-22} \text{ A/cm}^2$ (at 140 K)

particle identification and
background characterization
 $\sigma_{xy} \approx z$: fiducial volume definition

DAMIC CCD

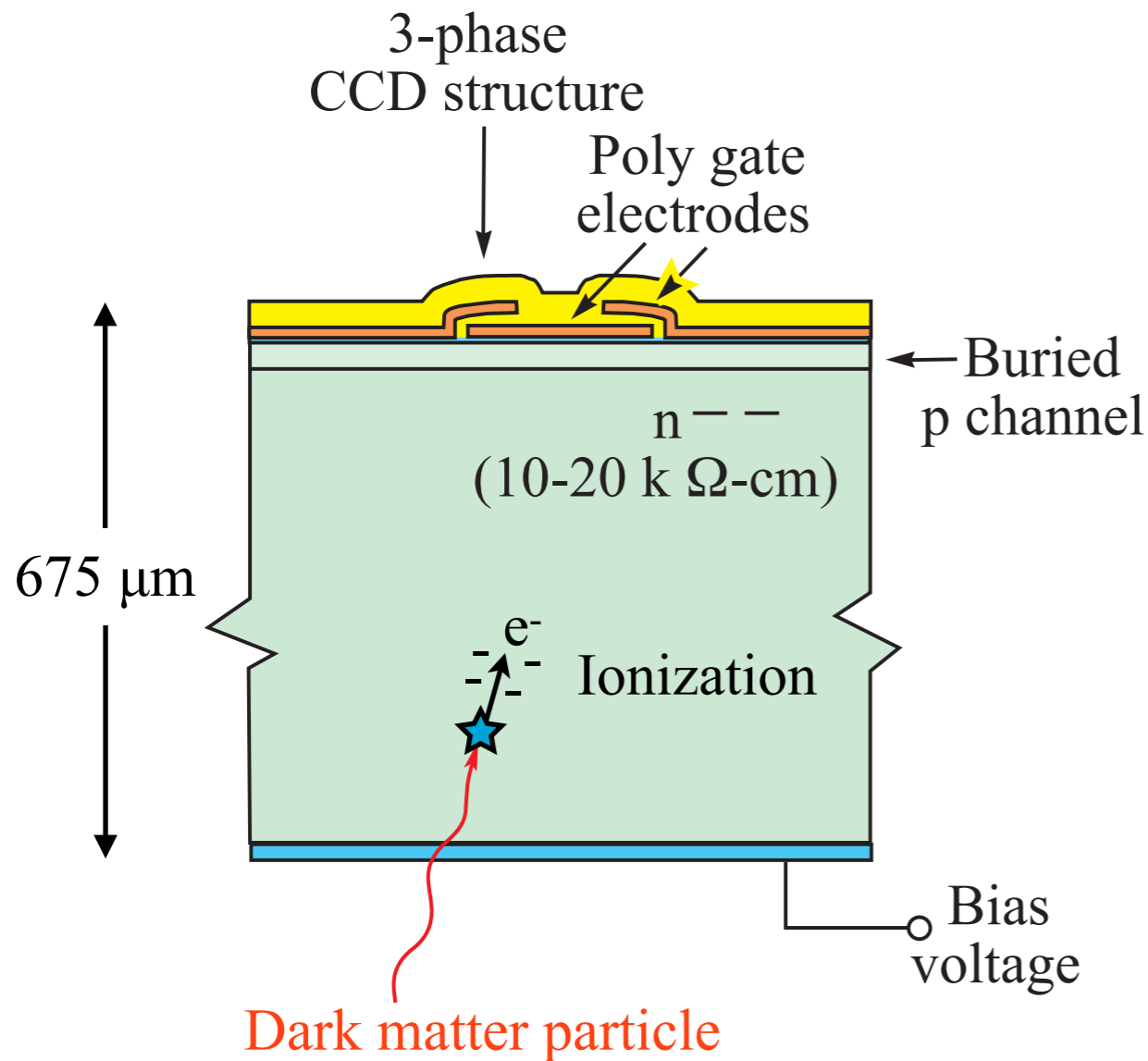

LBNL design

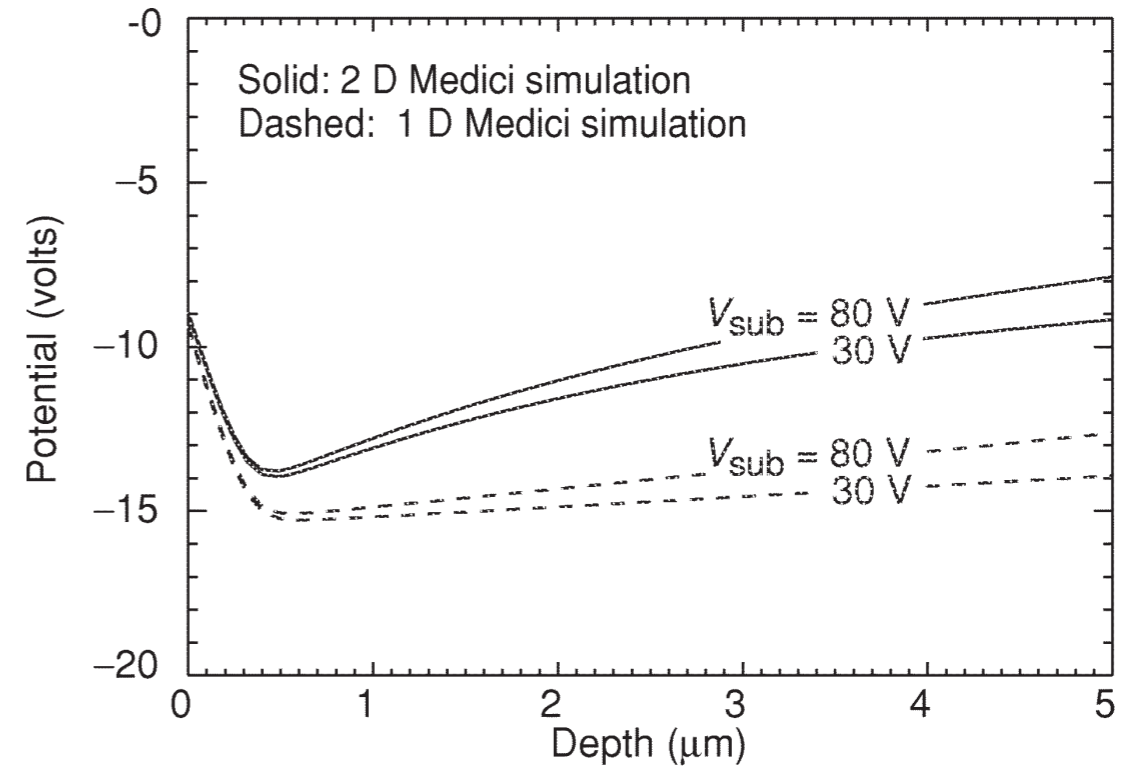
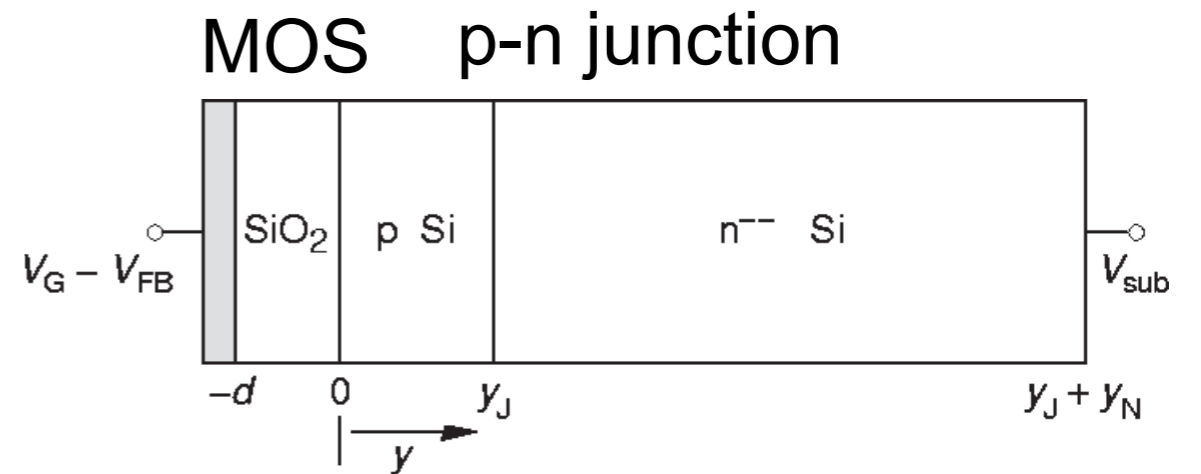

CCD readout

3x3 pixels CCD

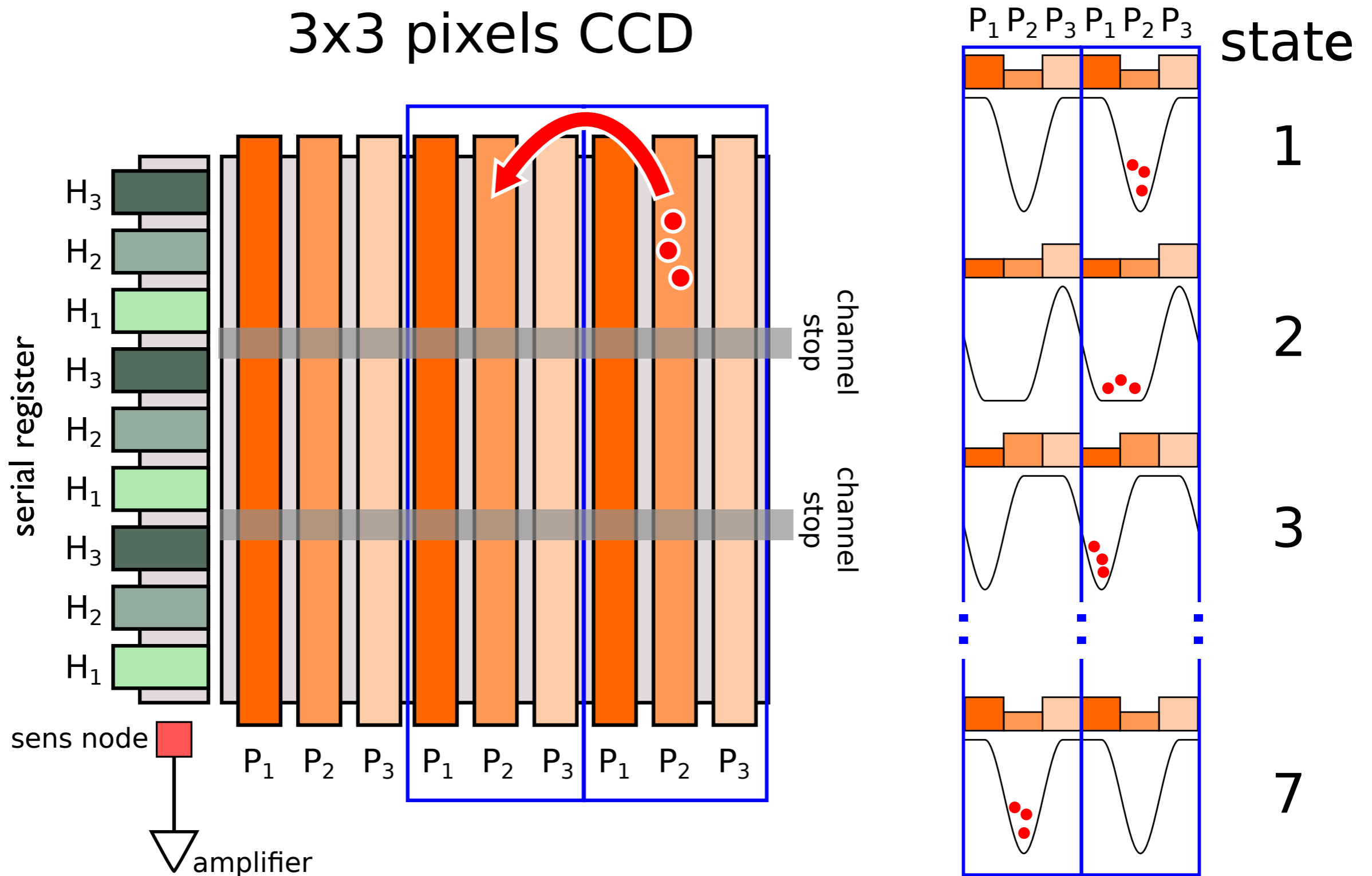

CDS readout

CDS: “Correlated double sampling”

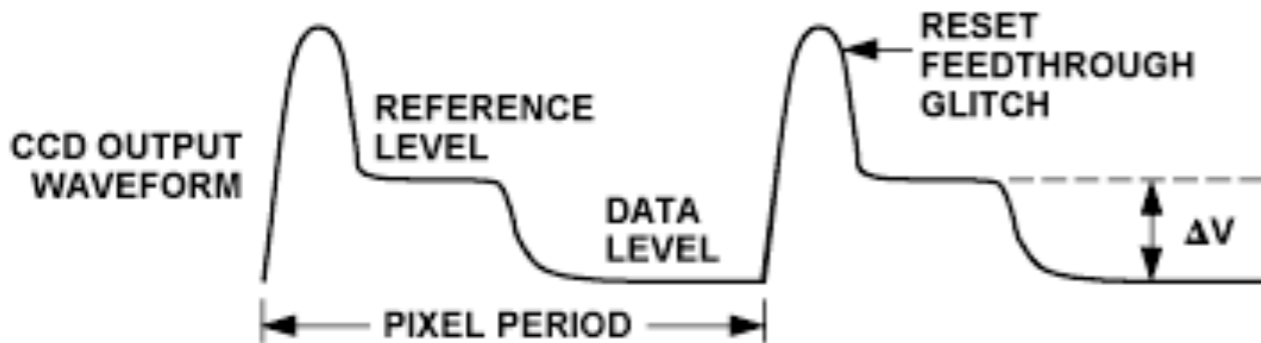
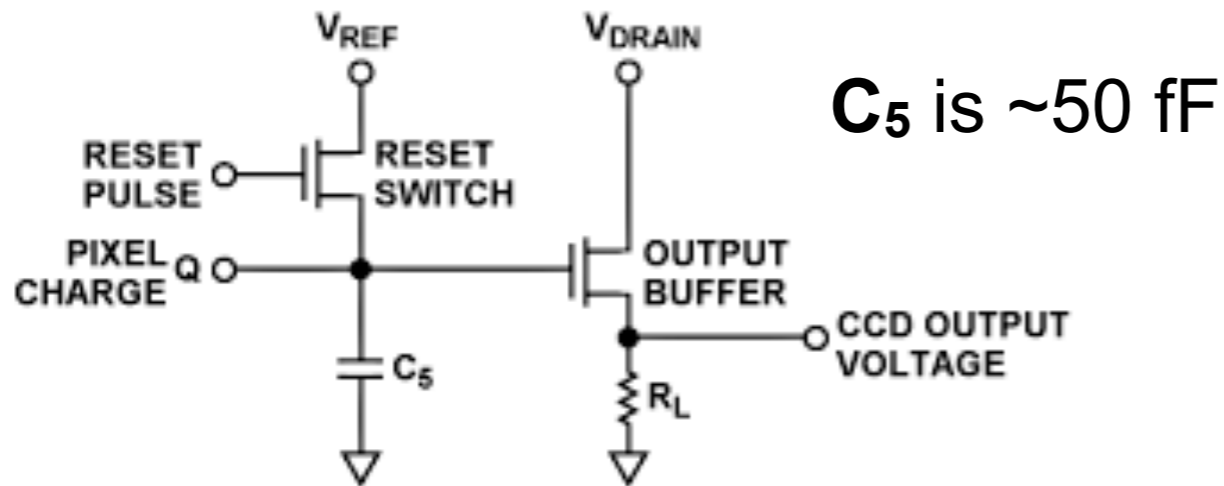

ΔV is $\sim 3 \mu\text{V}$ per e^-

“Skipper” readout can improve noise further

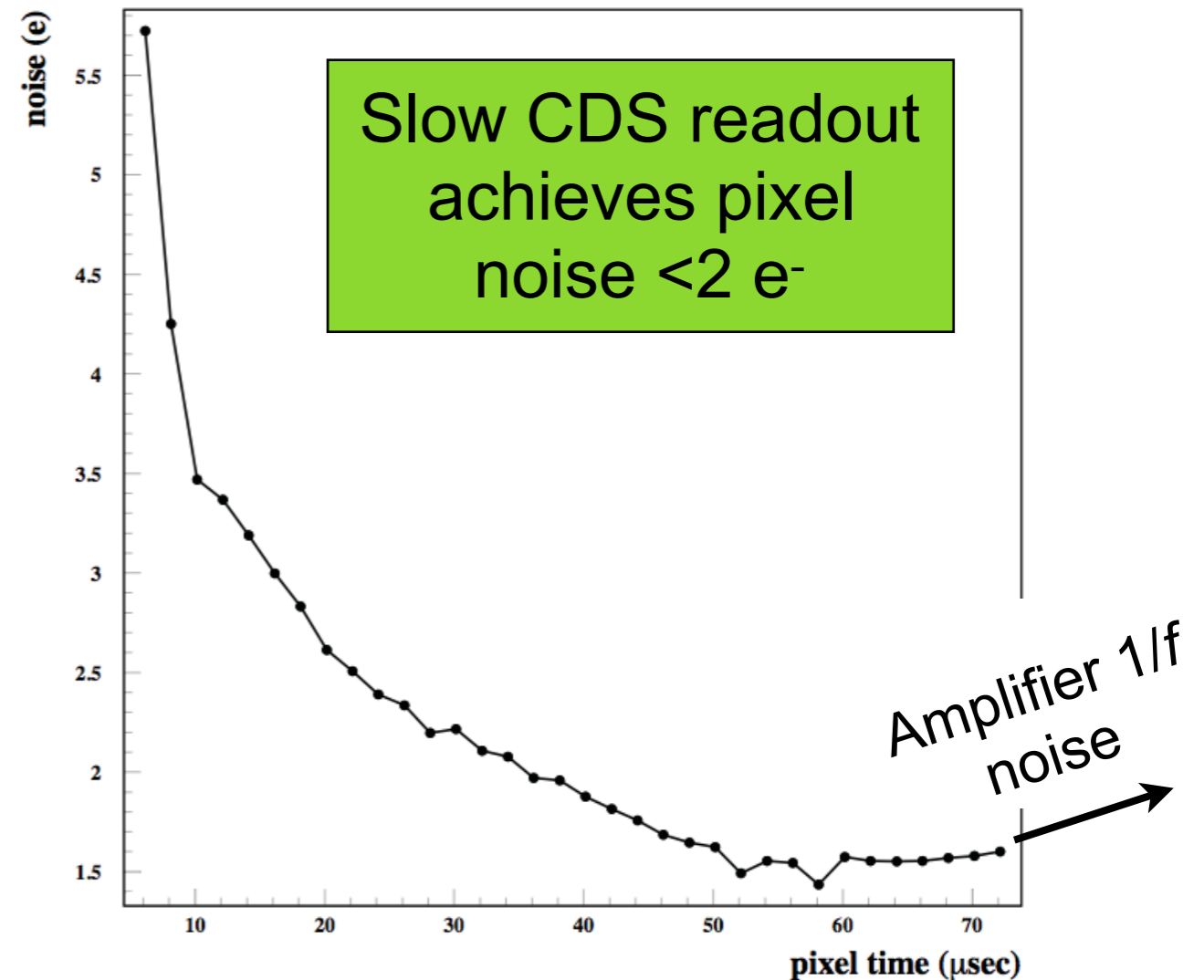

Flexibility in readout

Pixels can be readout in “groups” and the total charge estimated in a single measurement.

Less pixels but same noise *per pixel*!

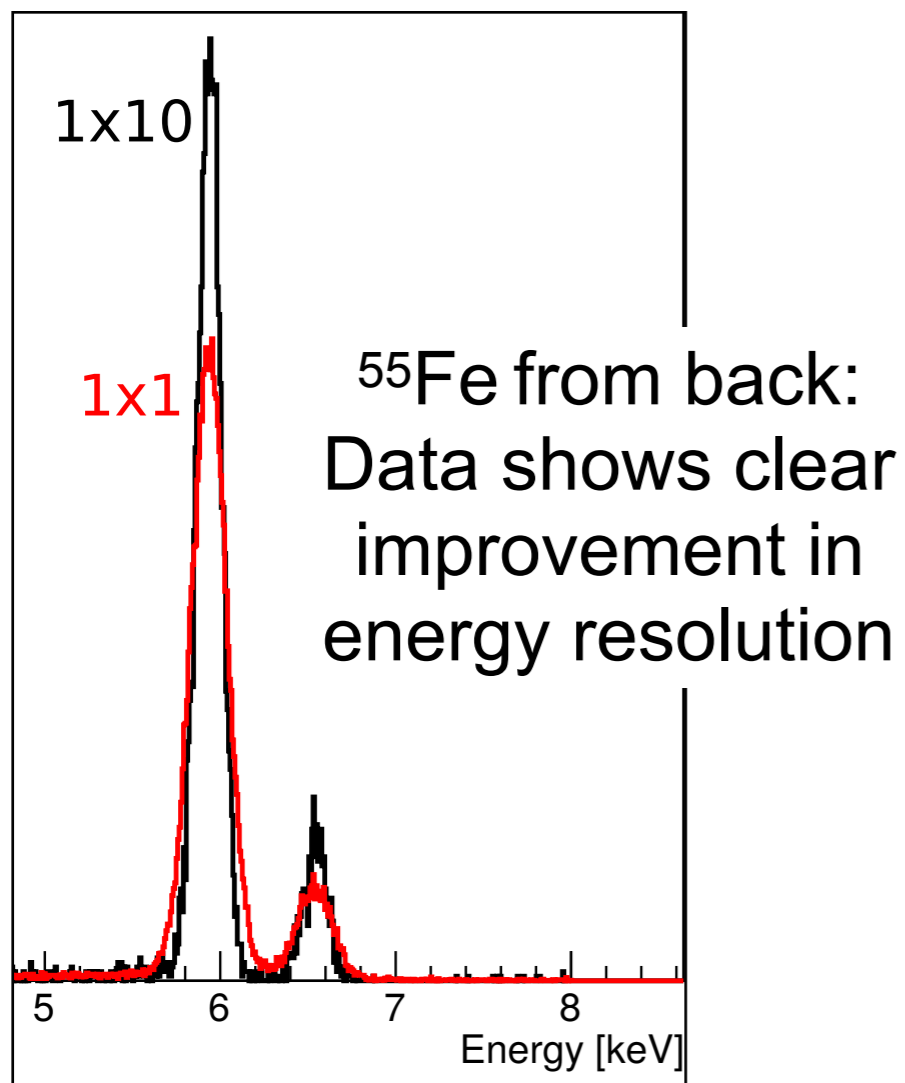

Loss of x, y and z information

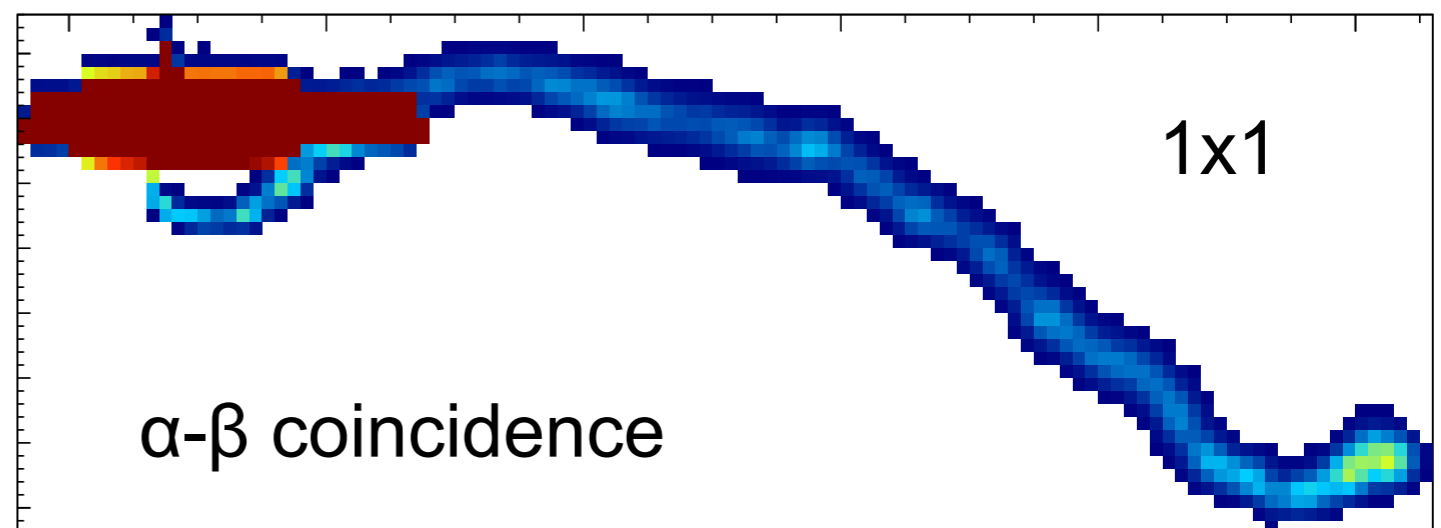
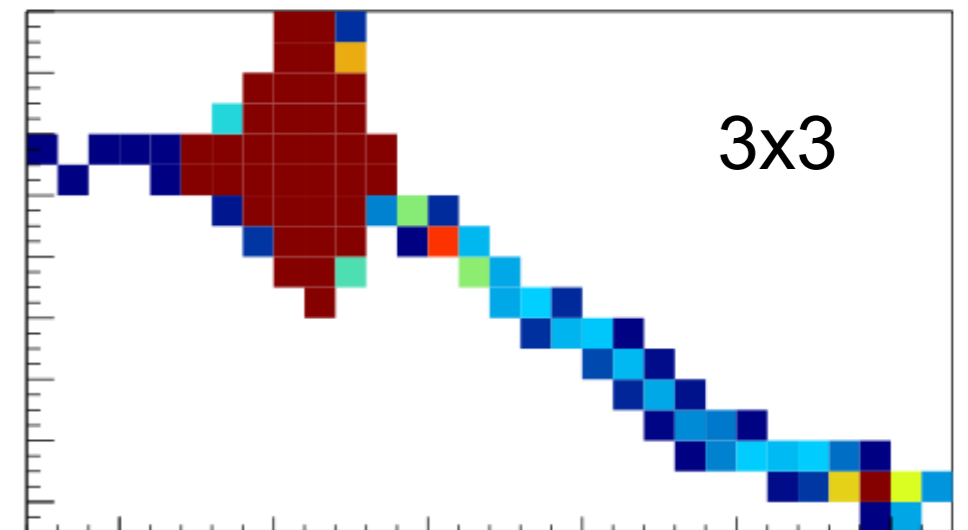

CCD characterization

Mn K_{α} from front and back

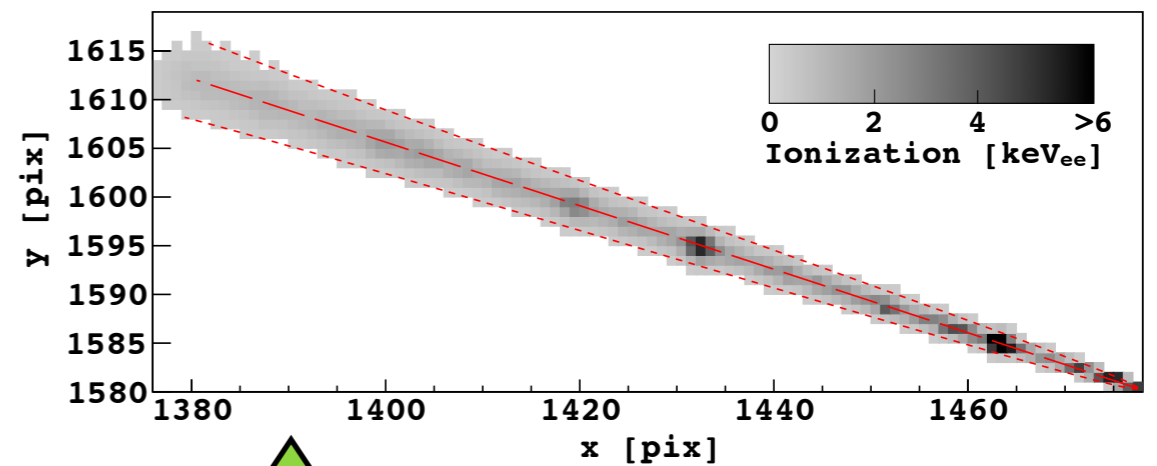
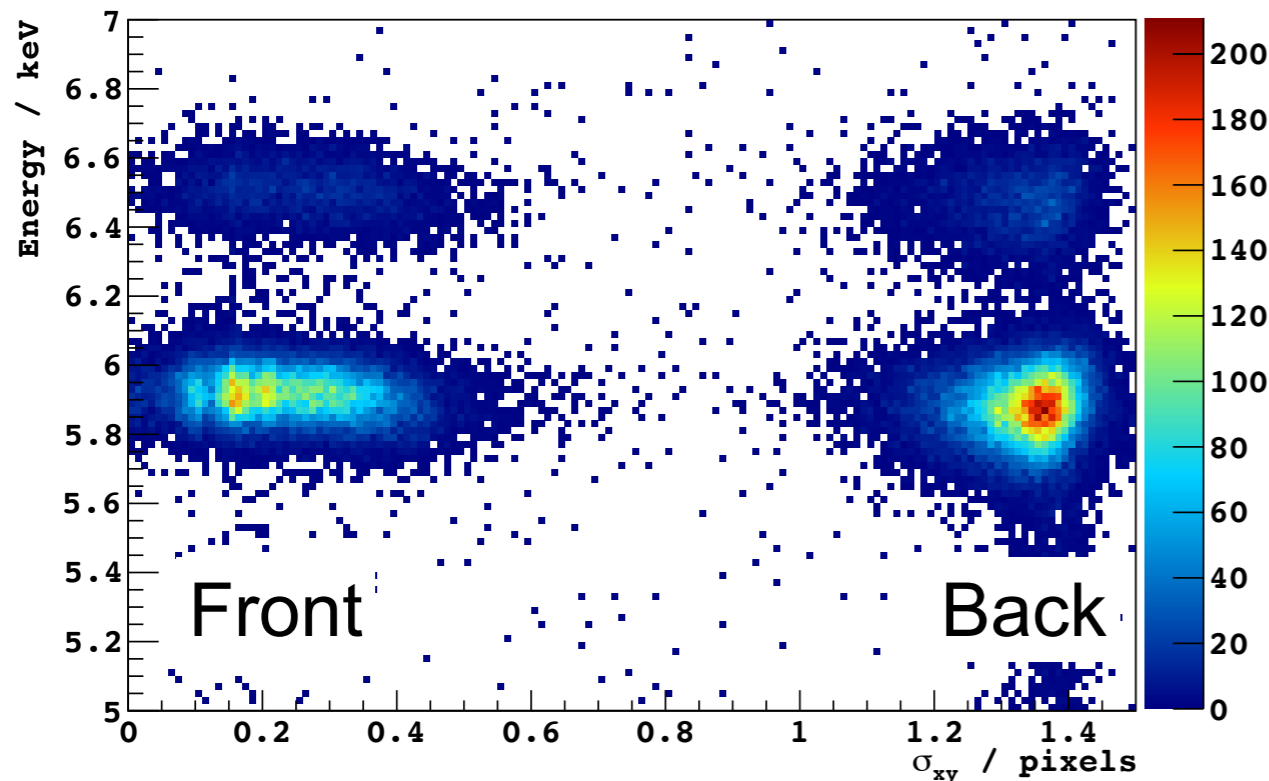

z reconstruction with X rays
and cosmic rays

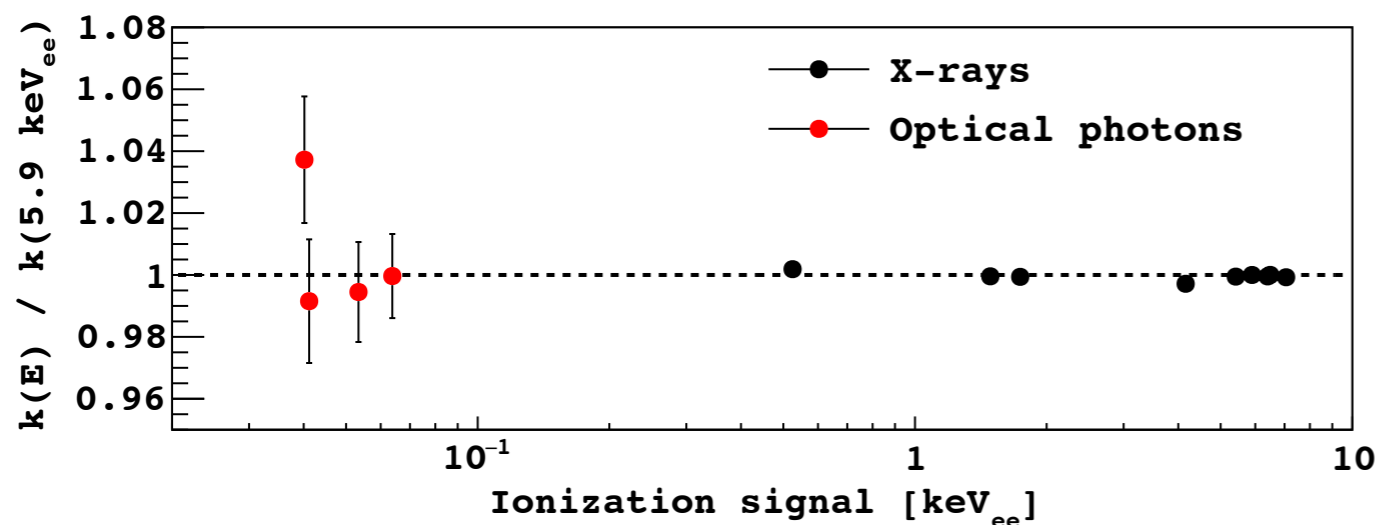

CCD linearity down
to 40 eV_{ee} with
optical photons

NR signal response

a) Cross-section of setup

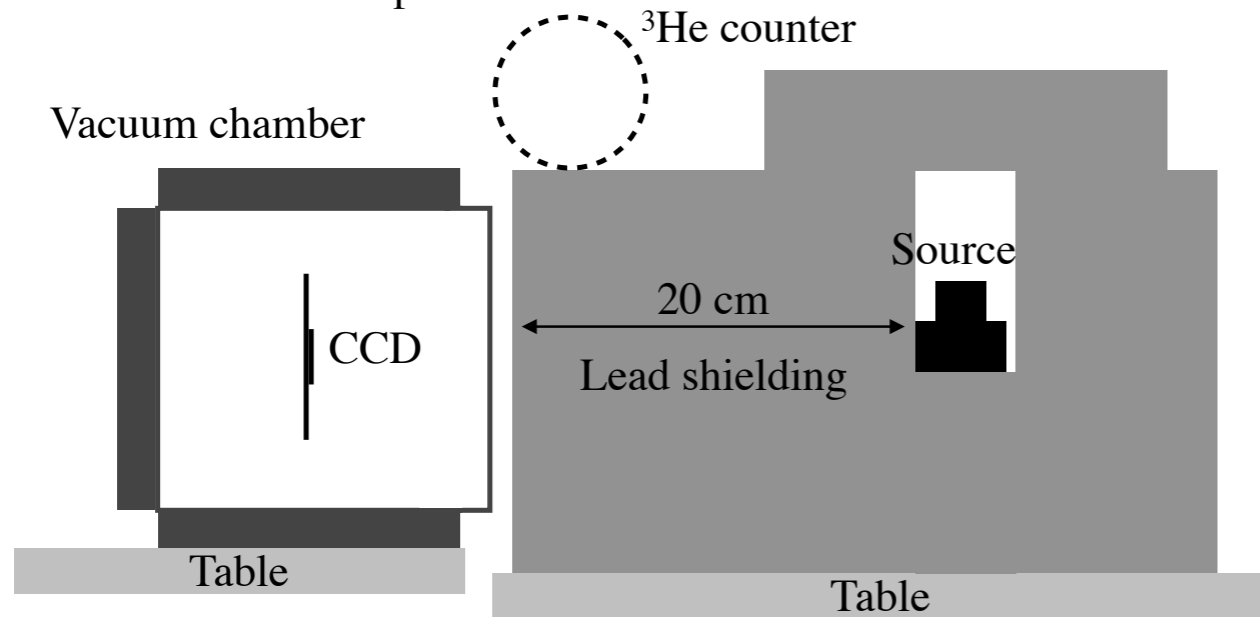

b) ^{124}Sb - ^9Be source detail

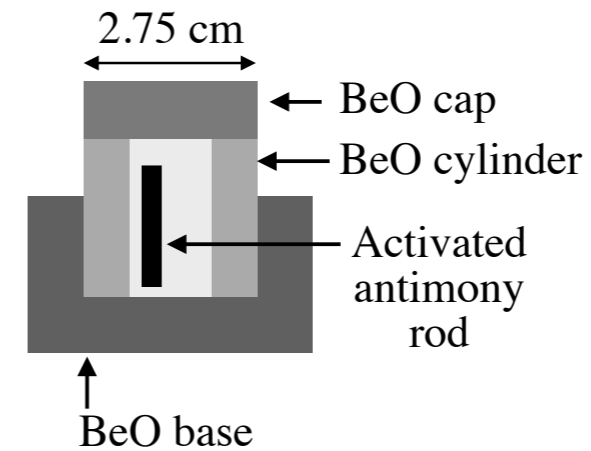

24 keV
neutrons
from
 $^9\text{Be}(\gamma, n)$
reaction

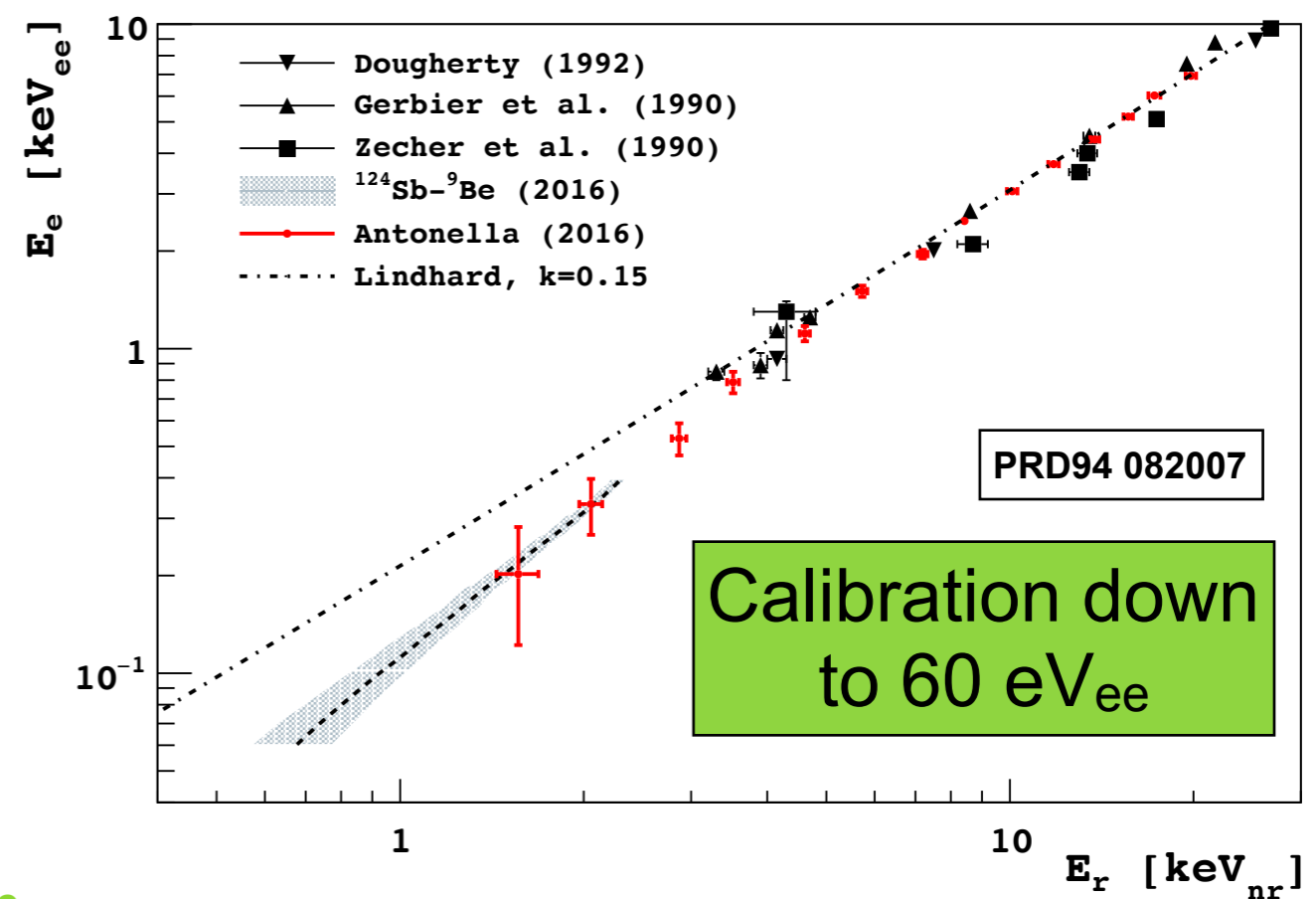
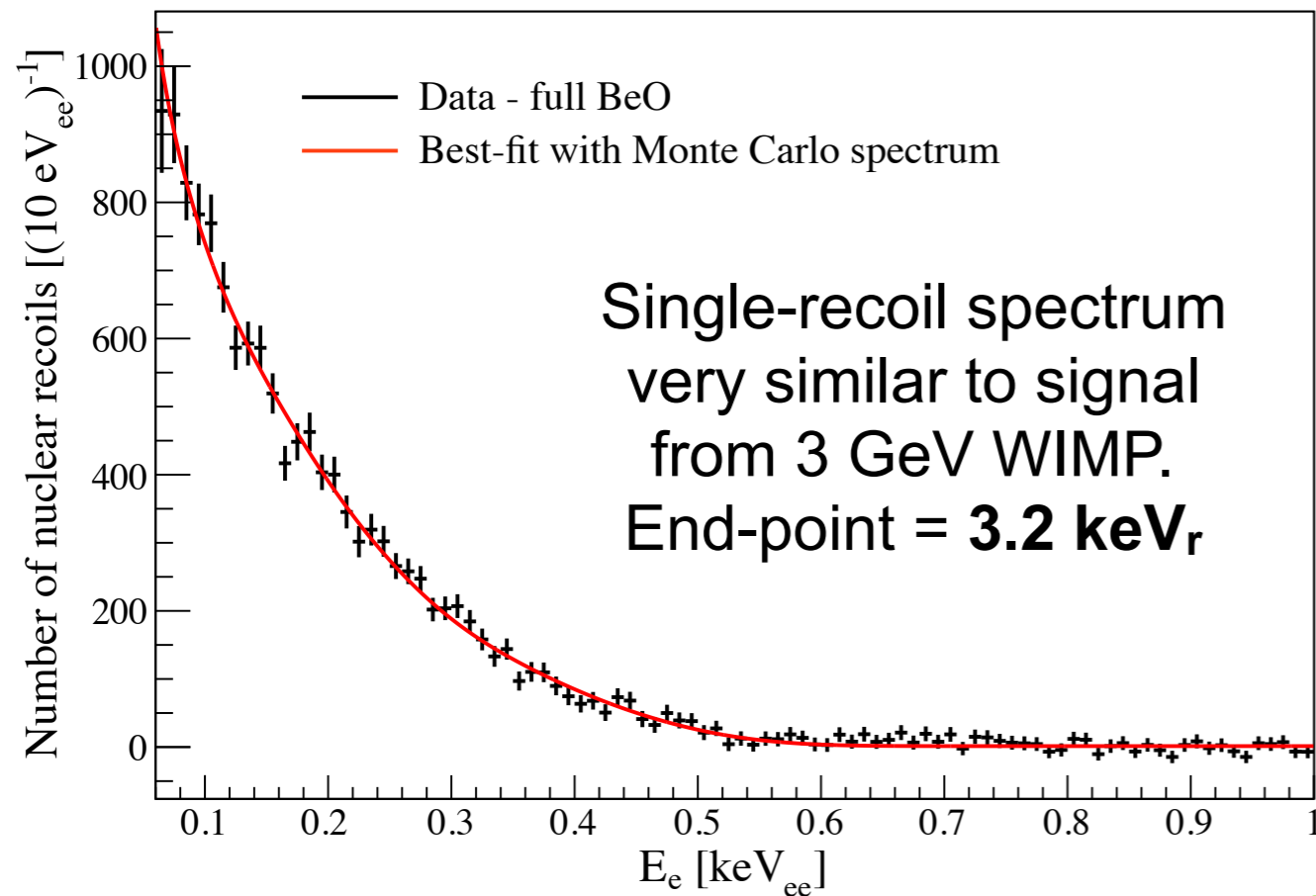

γ -ray response

Electron recoils in the bulk of the CCD from small-angle Compton scattering of γ rays are dominant background for DAMIC.

Linear spectrum, with slope dependent on the energy of the incident photons, with characteristic steps at the atomic binding energies.

Calibrated the parameters of a generic γ -ray model with ^{241}Am and ^{57}Co sources.

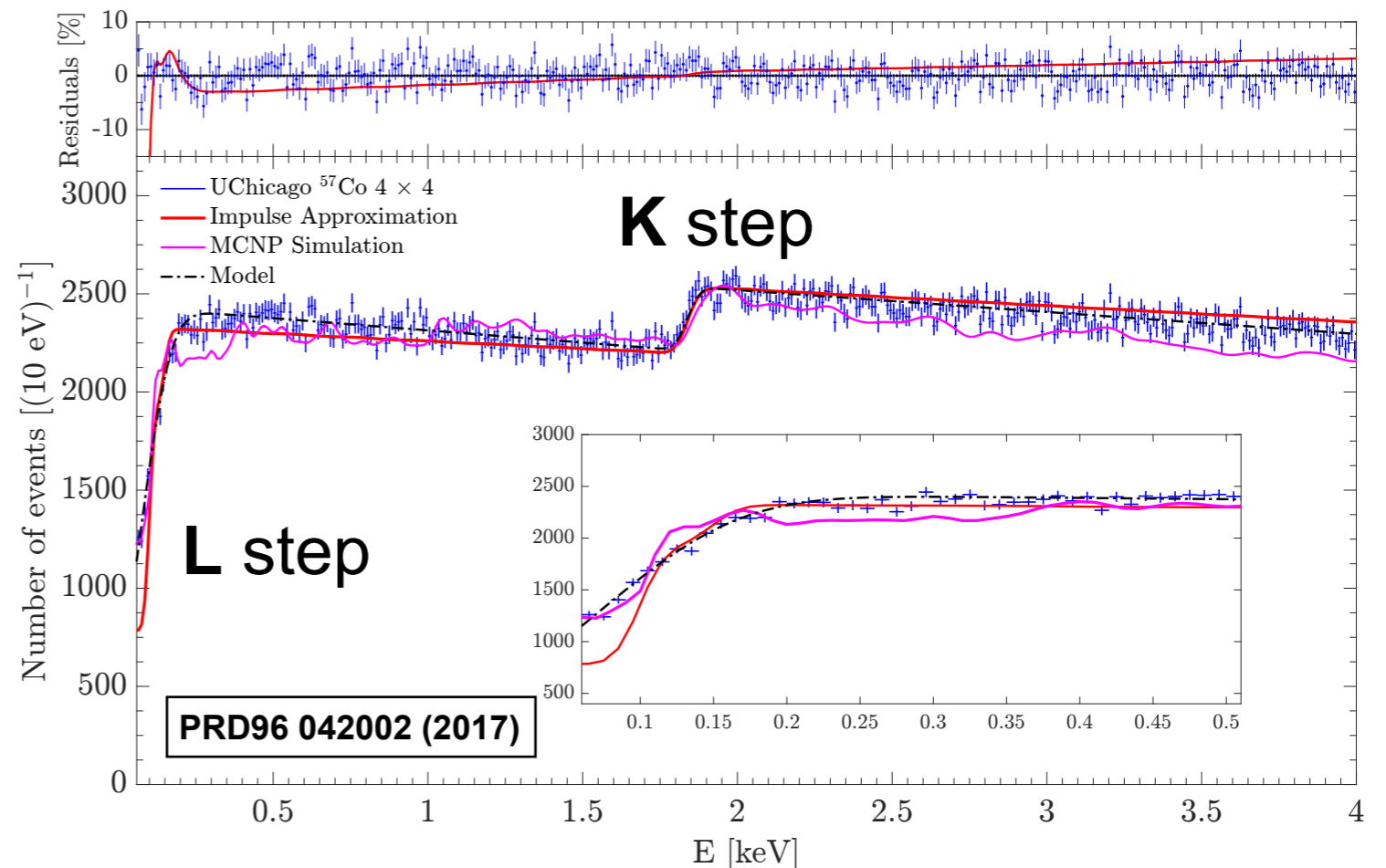
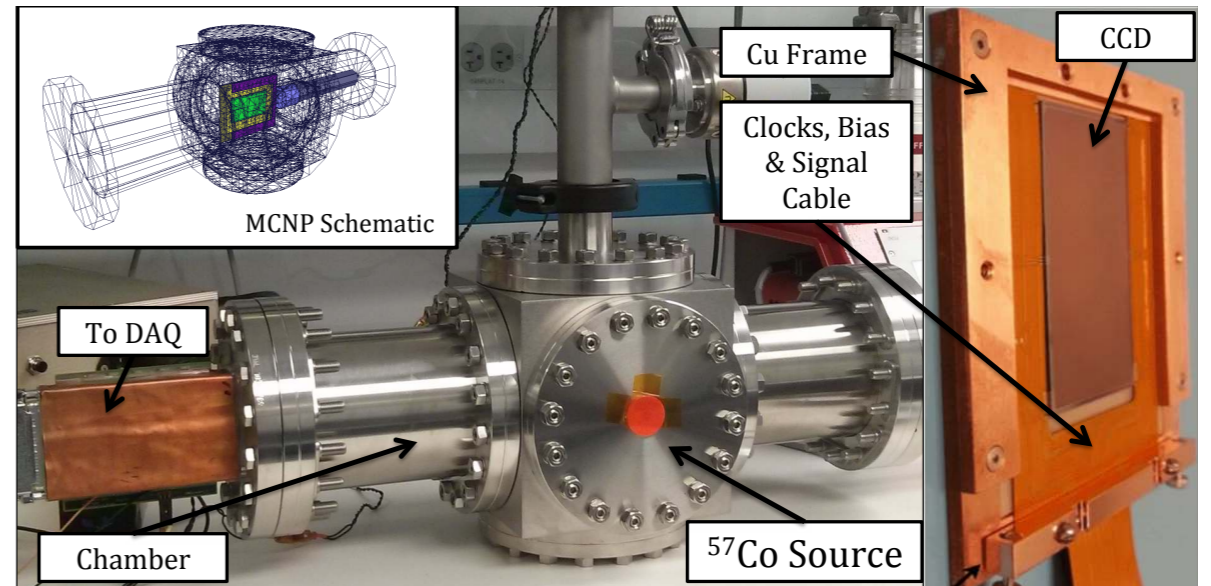

2 km underground

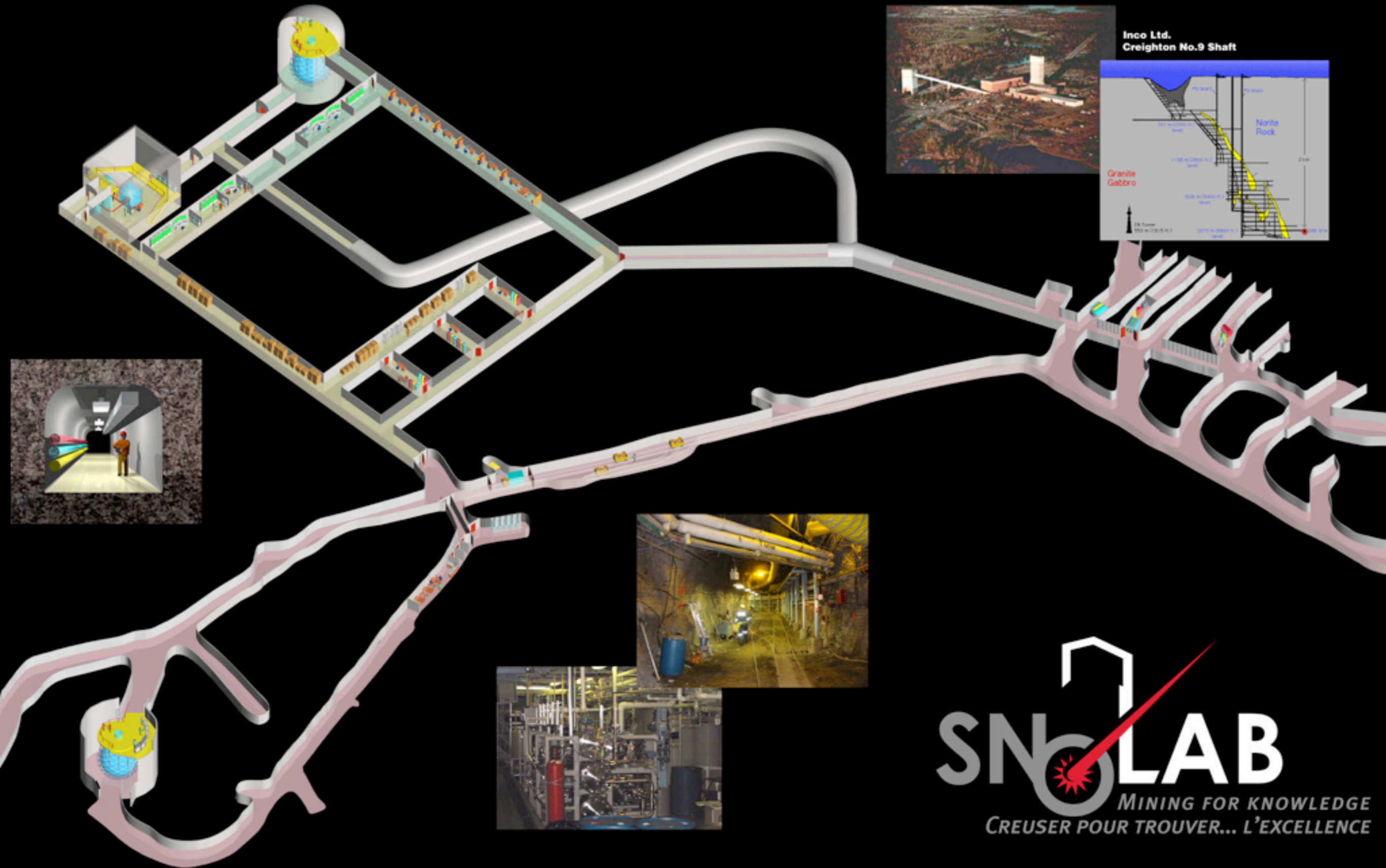

Inco Ltd.
Creighton No.9 Shaft

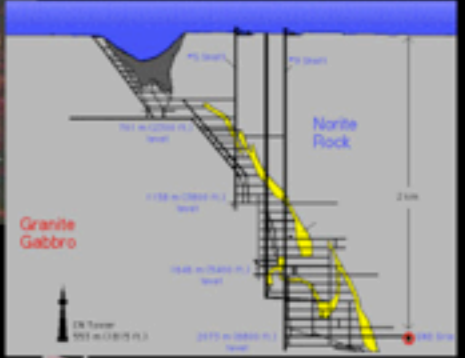

SNO+ LAB
MINING FOR KNOWLEDGE
CREUSER POUR TROUVER... L'EXCELLENCE

SNOLAB Installation

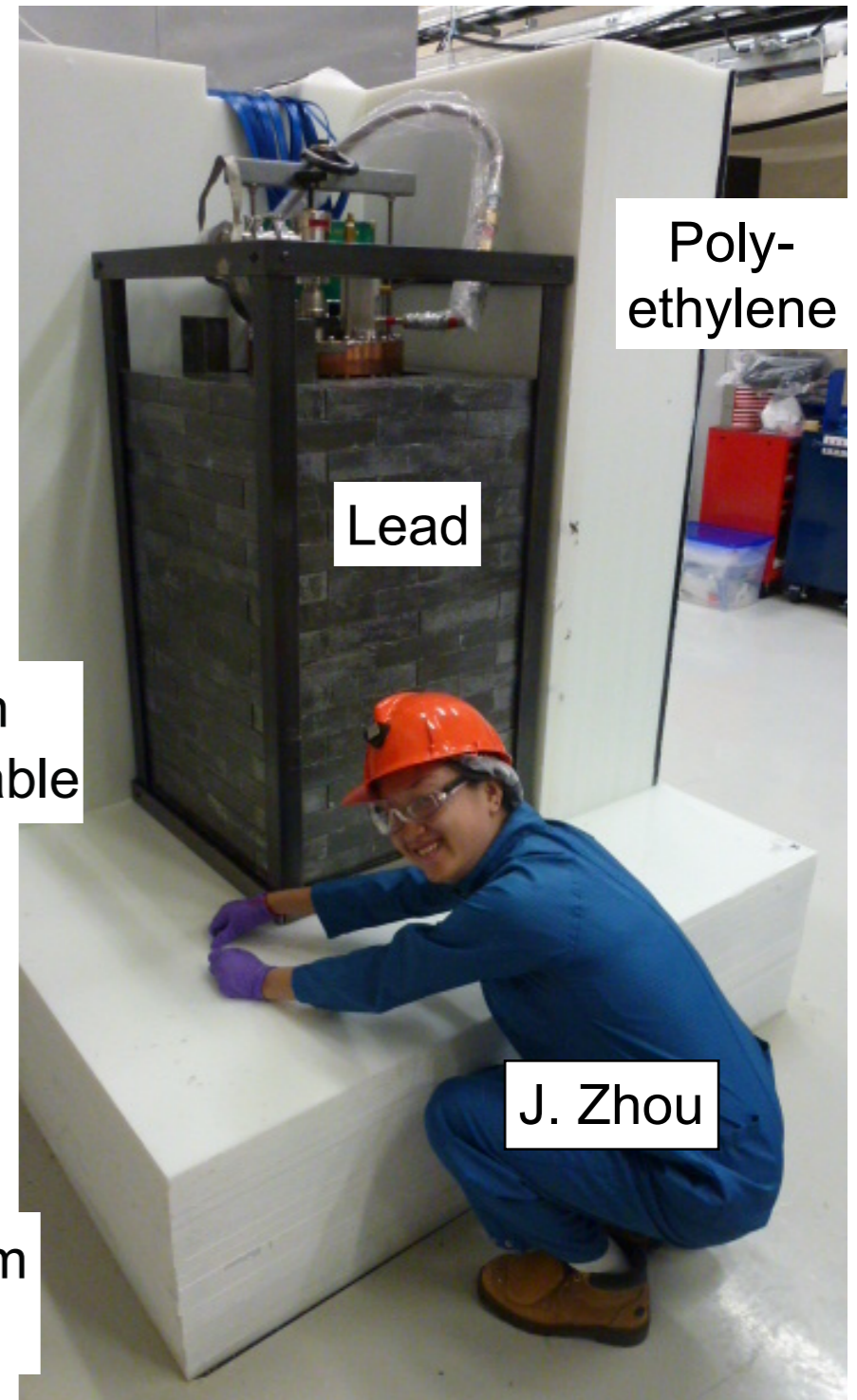
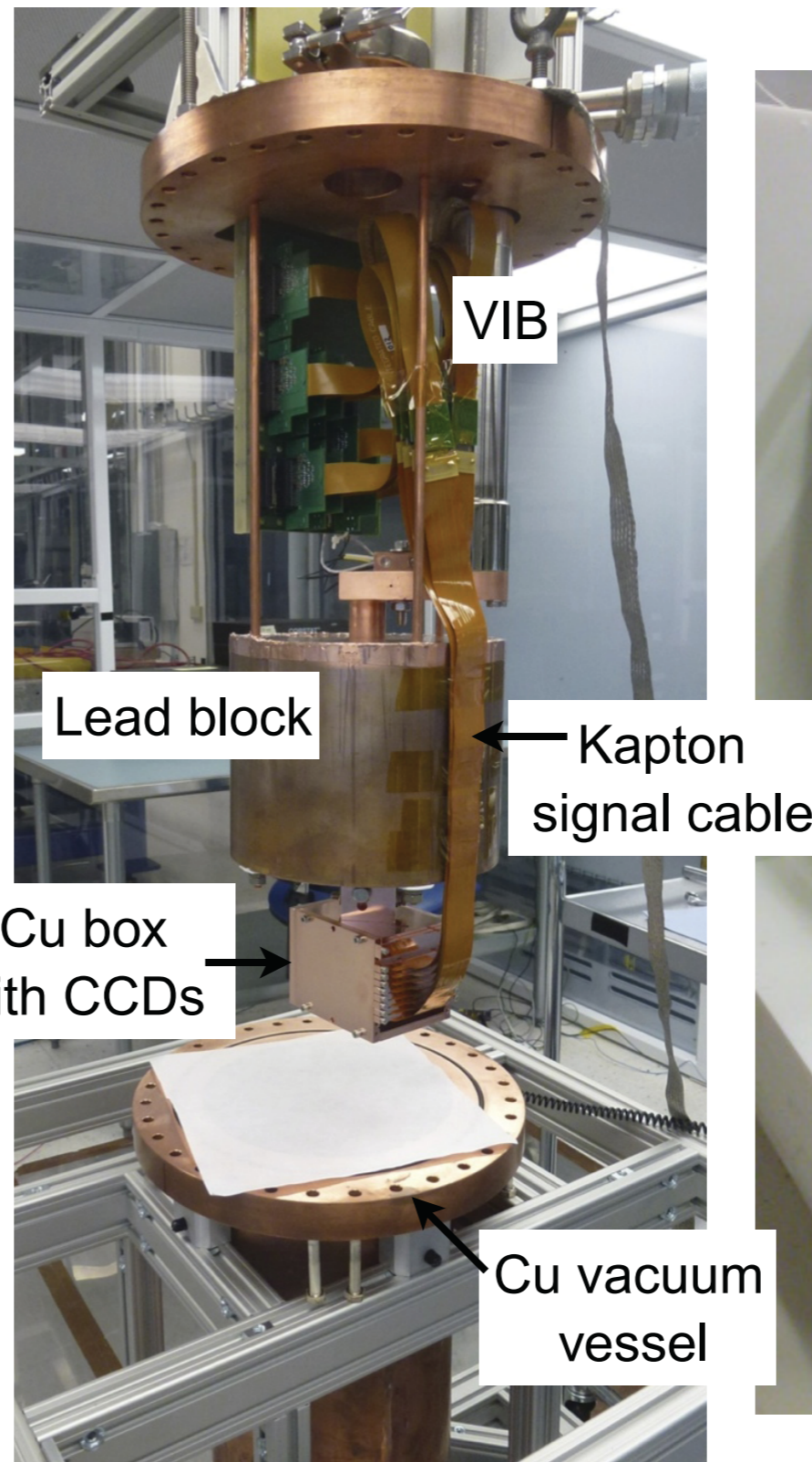
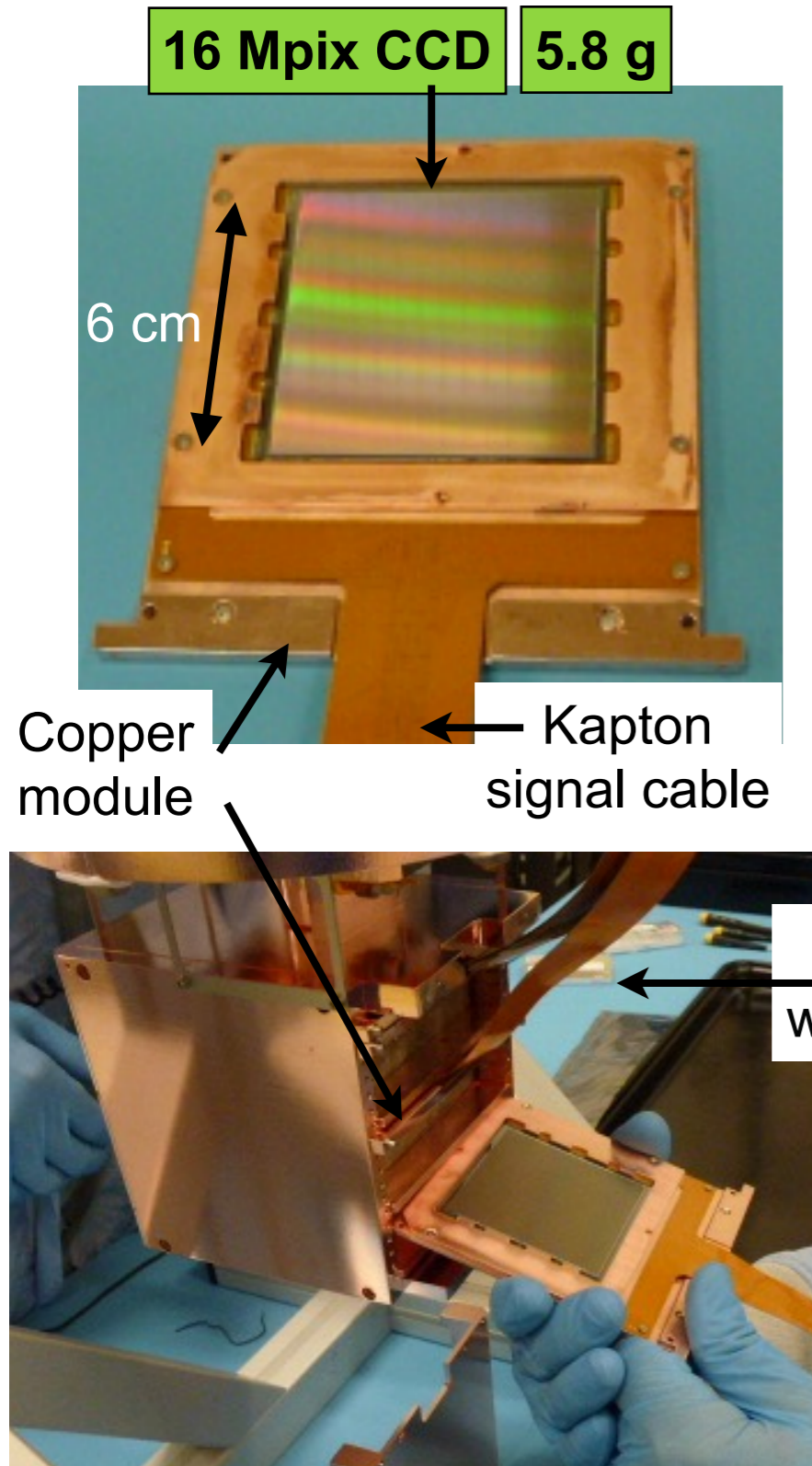

Timeline

- ▶ First CCDs installed at SNOLAB in December 2012.
- ▶ Three years 2013-2015 to achieve low radioactive background.
- ▶ WIMP and HP results with R&D data.

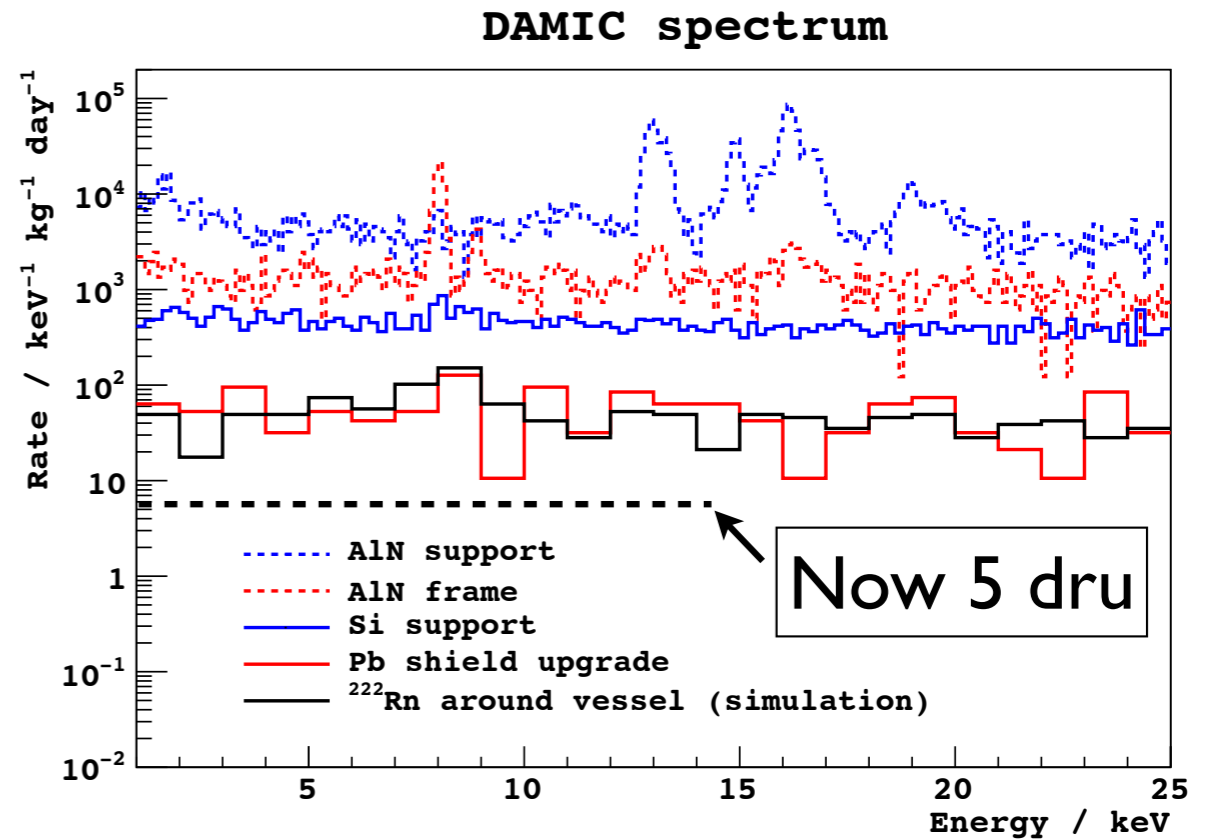
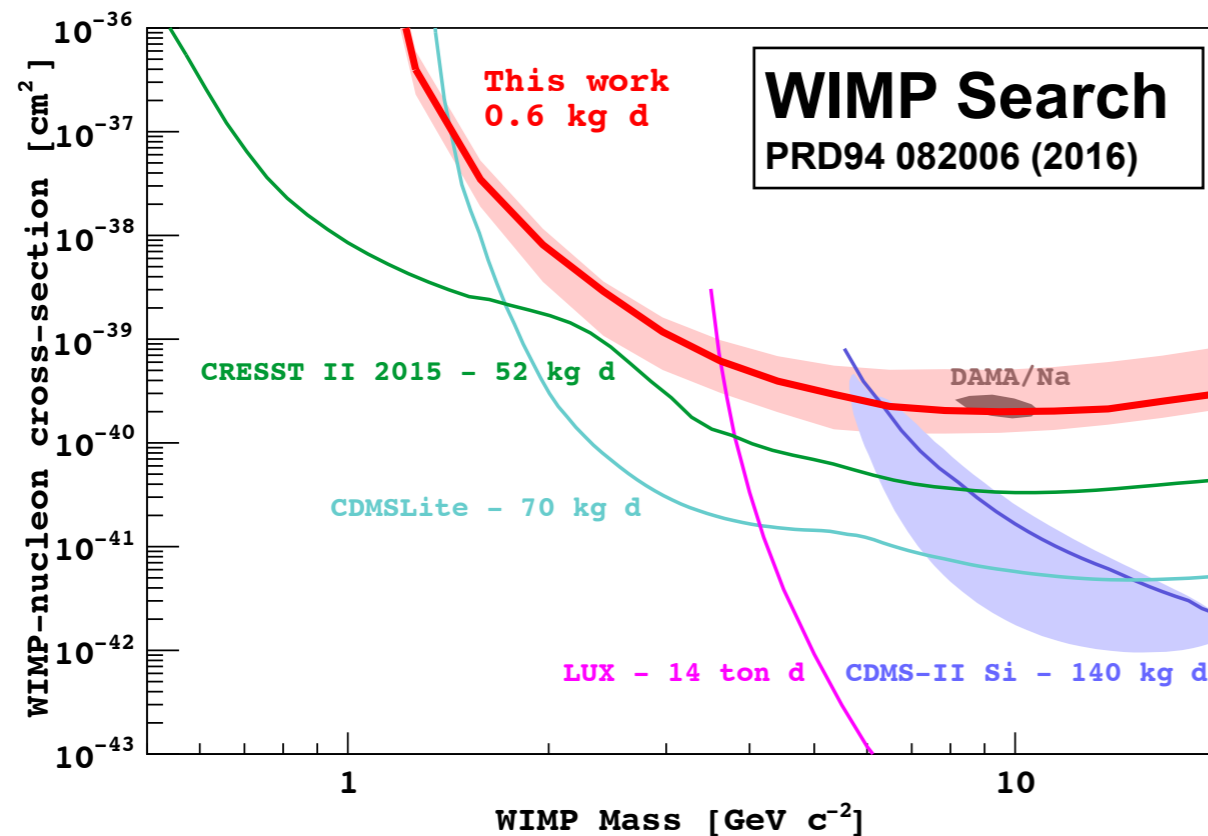

- ▶ First deployment early 2016: problems with mechanics of CCD package.
- ▶ Second deployment early 2017.
- ▶ Taking data since.

Background at SNOLAB

Extensive selection of copper, special machining and chemical cleaning.

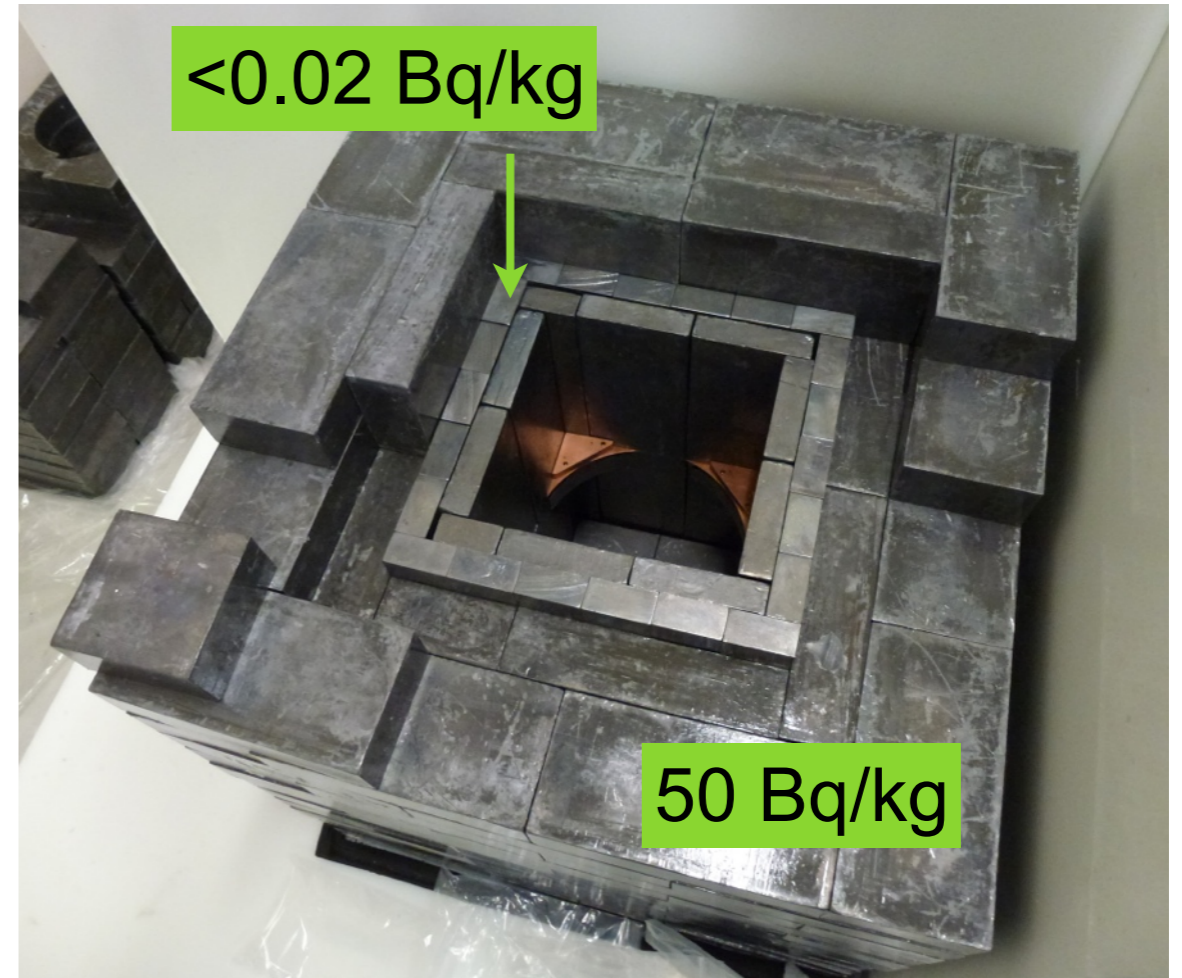

Lead shielding to stop external γ s:
Inner 2" of lead is ancient to stop
bremsstrahlung from ^{210}Bi decay.

Nitrogen purge around lead to
suppress radon $\ll 1 \text{ Bq/m}^3$.

Current event rate $5 / \text{keV}_{ee} / \text{kg} / \text{d}$.

Hidden photon search

Absorption of hidden-photon dark matter.

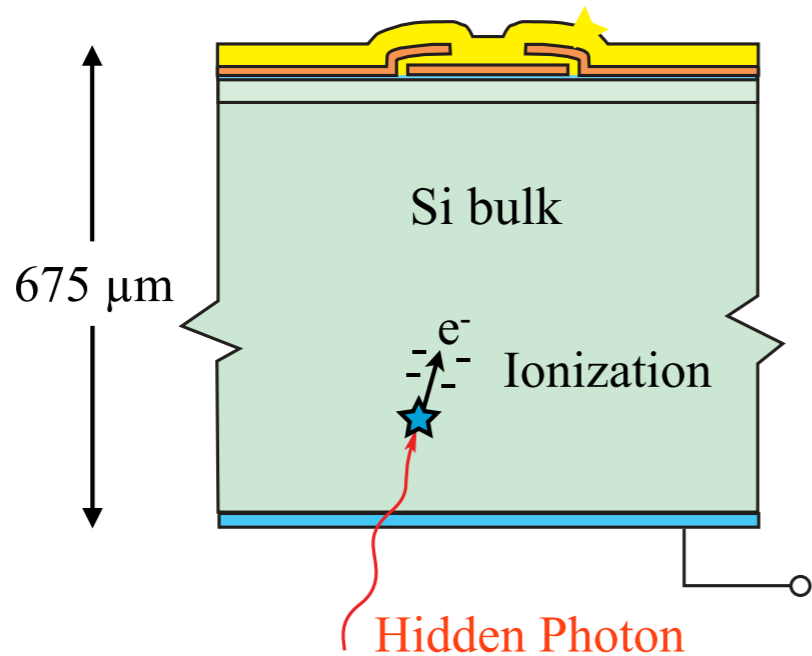

~1 week of data with 1 CCD.
Leakage current $4 \text{ e}^- \text{ mm}^{-2} \text{ d}^{-1}$.

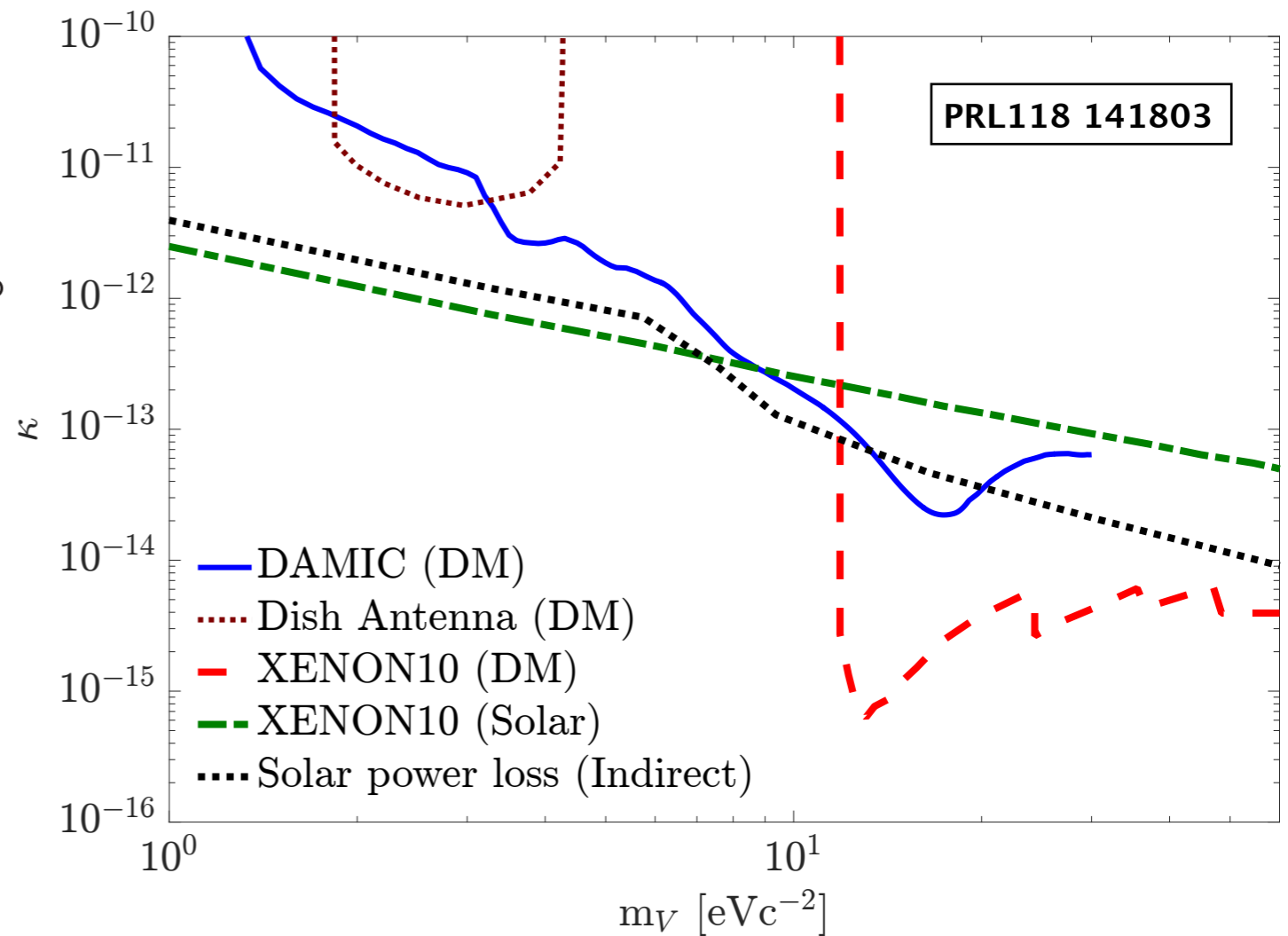
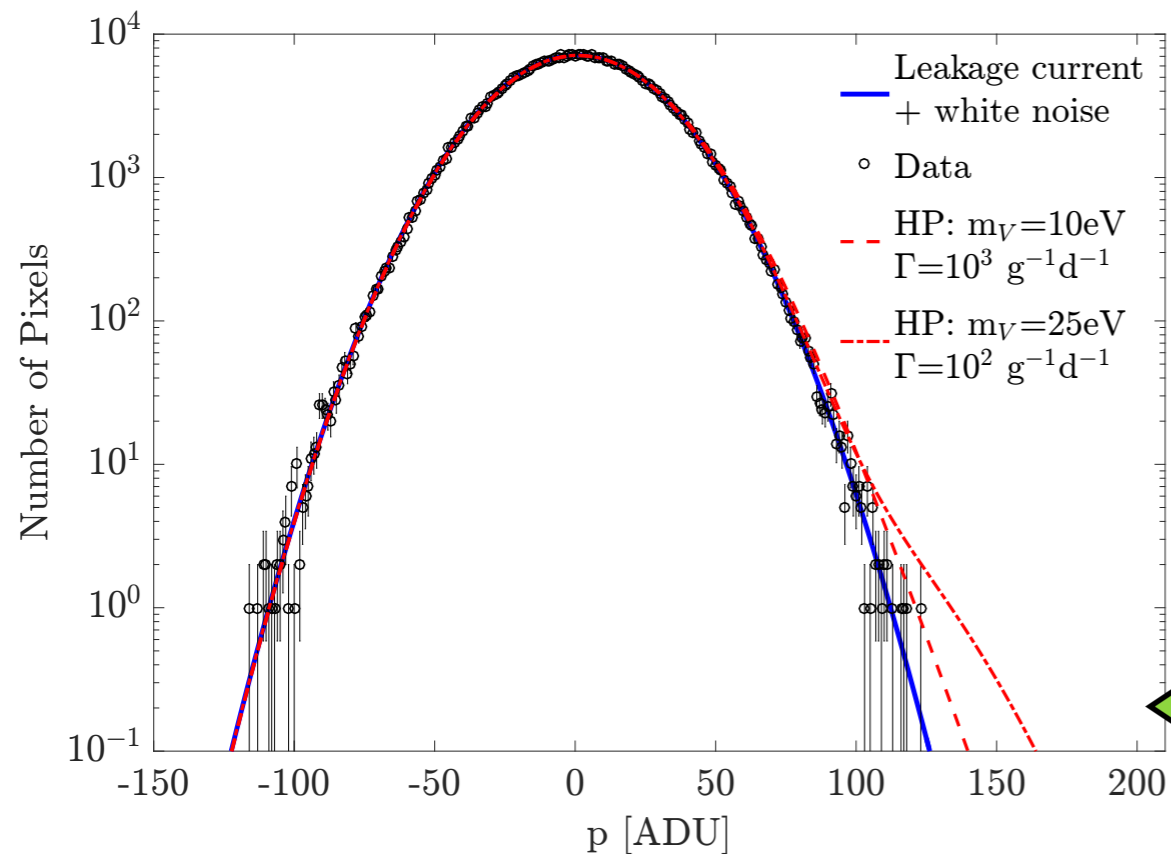

Pixel distribution consistent with white noise + uniform leakage current

Current status

- ▶ **7 CCDs** in stable data taking since 2017 (1 CCD sandwiched in ancient lead).
- ▶ **40 g** target mass.
- ▶ Operating temperature of **140K**.
- ▶ **Exposure for image: 8h and 24h** (each image acquisition is followed by a “blank” exposure).
- ▶ **7.6 kg-day** of data for **background** characterization in 1x1 format.
- ▶ So far, **4.6 kg-day** of data collected for **DM search** in **1x100** format.

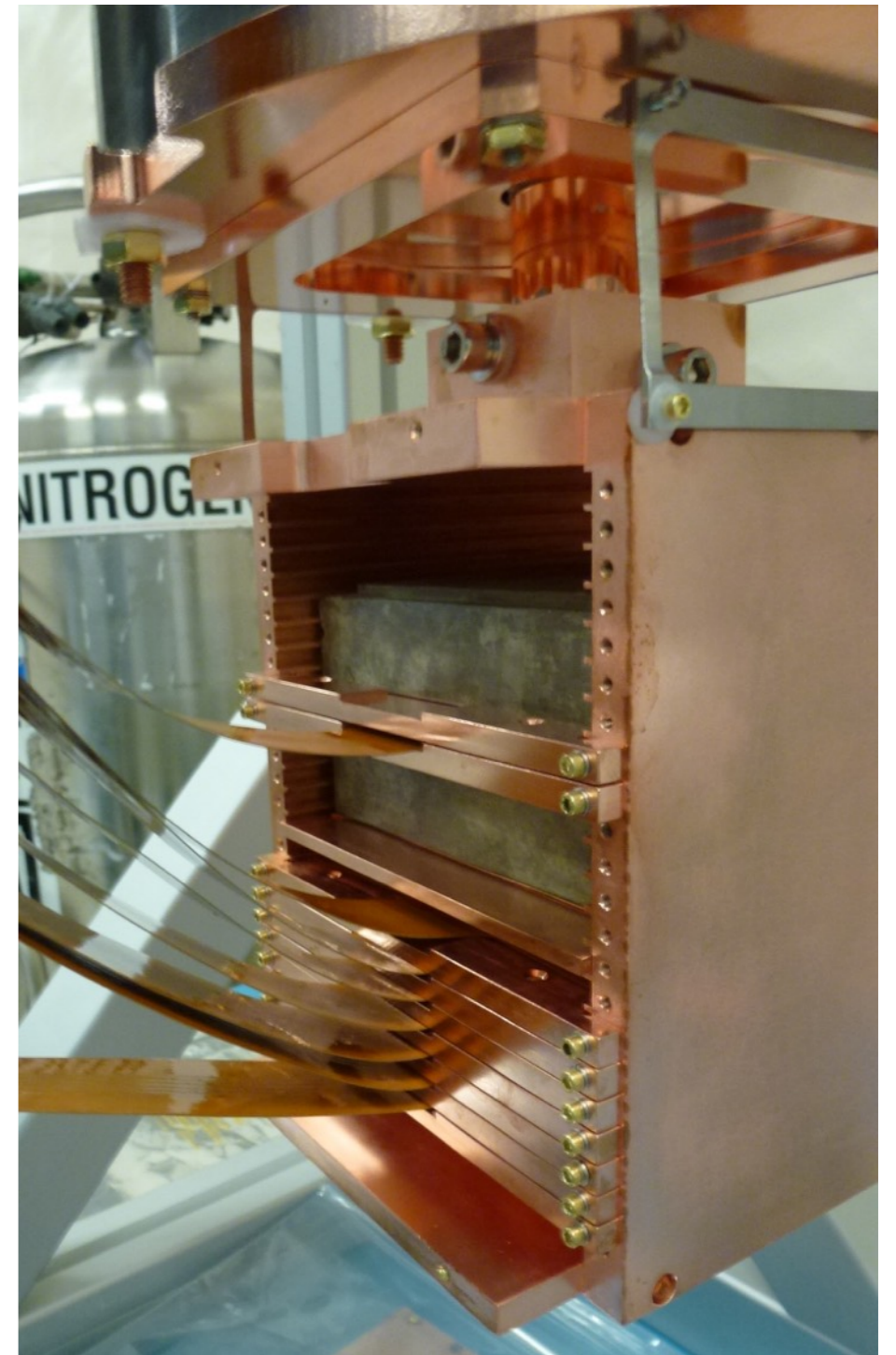

Event selection

- ▶ Pedestal and correlated noise subtraction (hot pixels among several images masked)
- ▶ LL fit of the signal in a moving window across the image

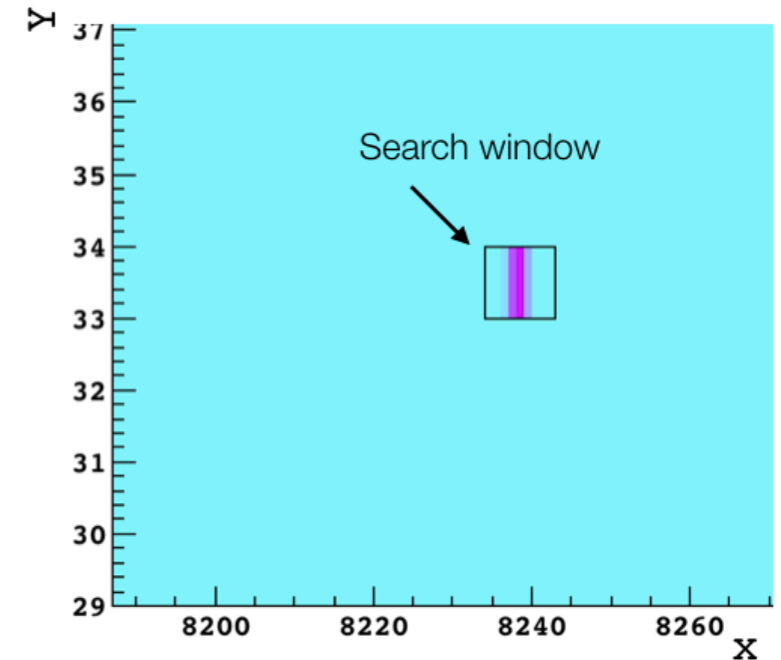

$$\Delta LL = \mathcal{L}_n - \mathcal{L}_s$$

flat noise \curvearrowright \mathcal{L}_n \mathcal{L}_s Gauss signal + flat noise

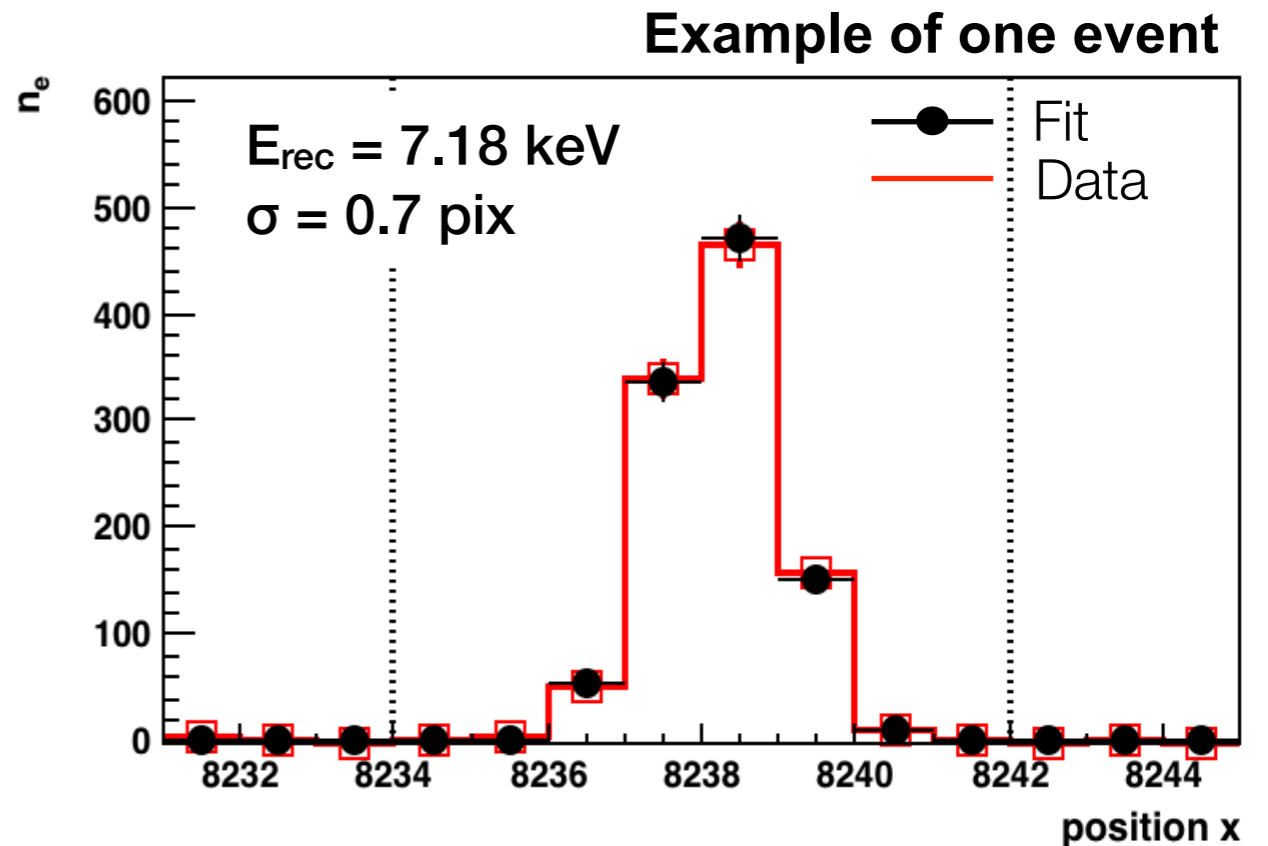
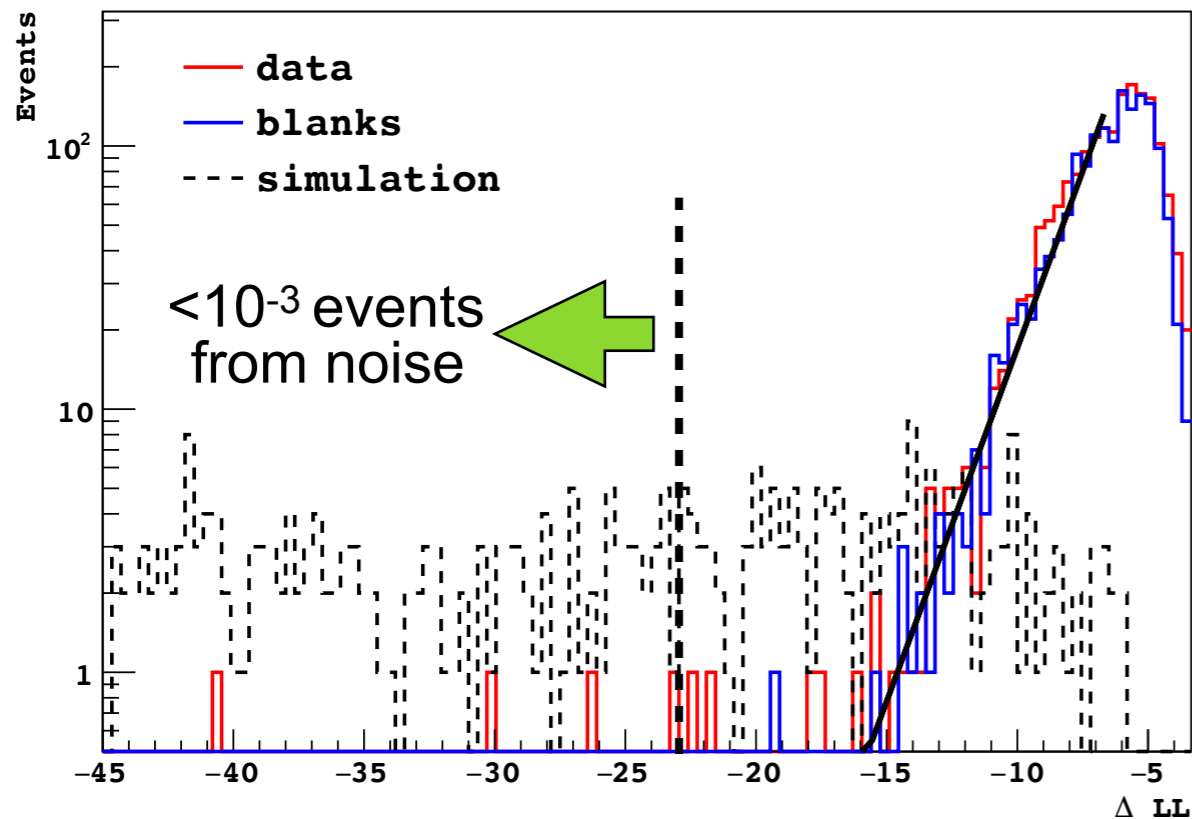

Surface background

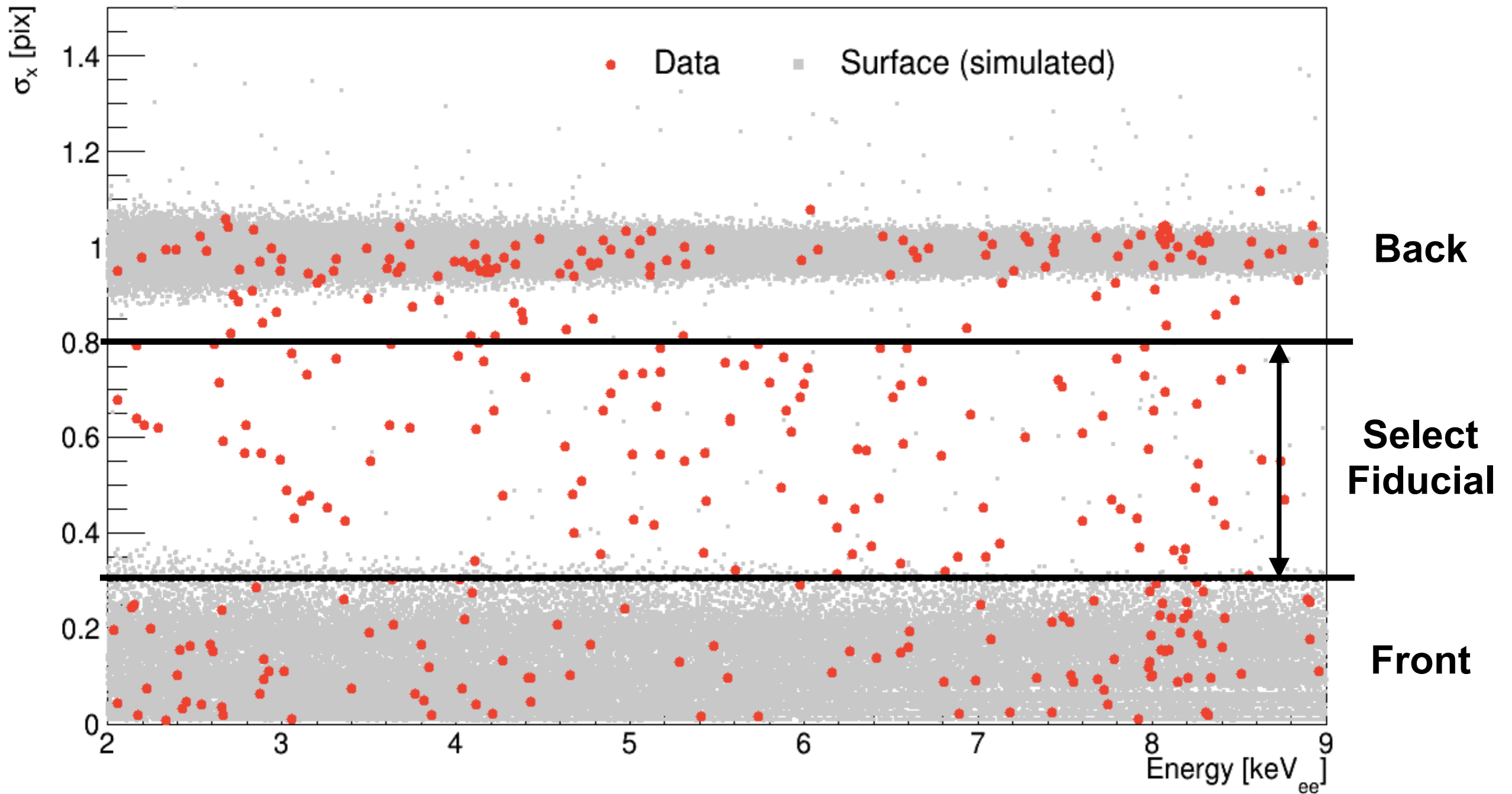

Acceptance

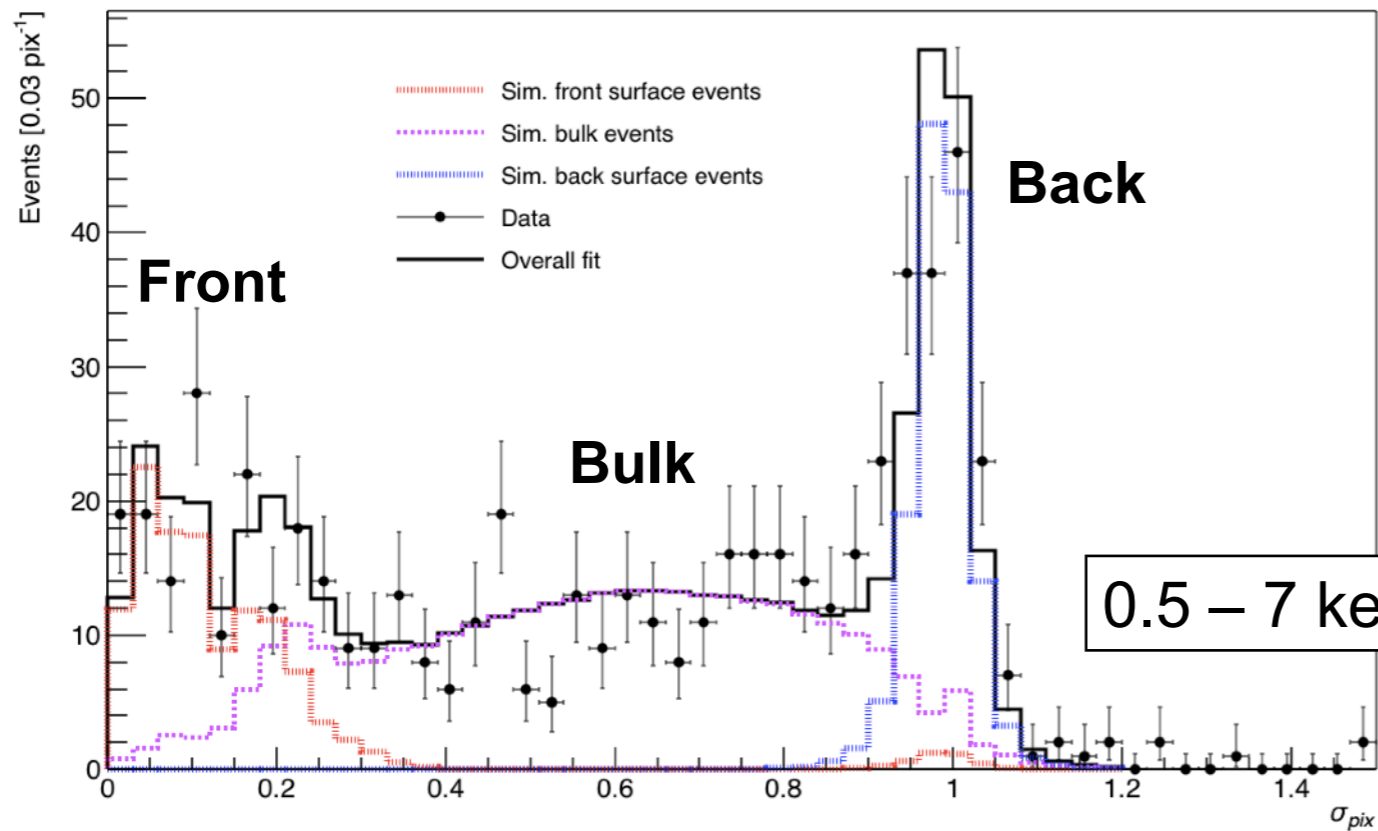

Background + signal model from simulations

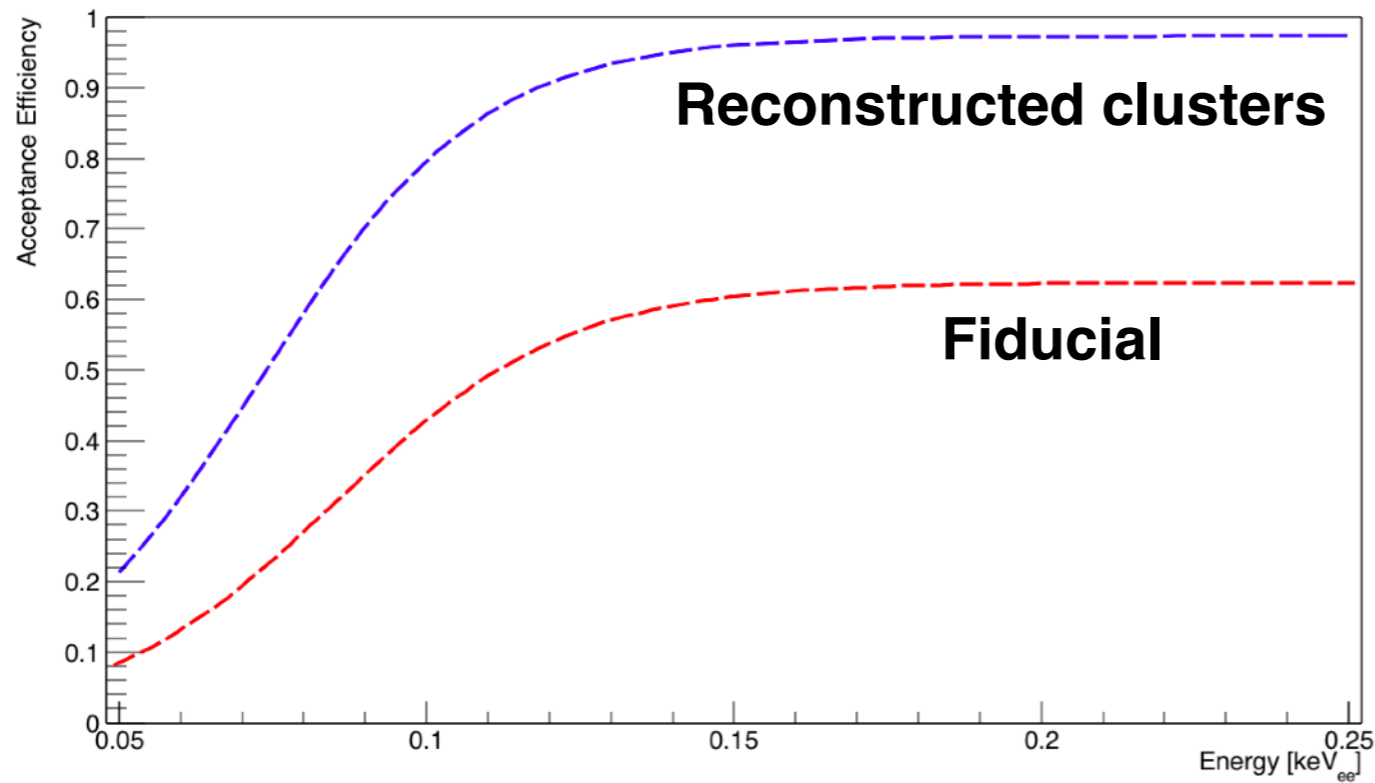

Acceptance for bulk events

Software energy threshold: 50 eV_{ee}

Energy spectrum

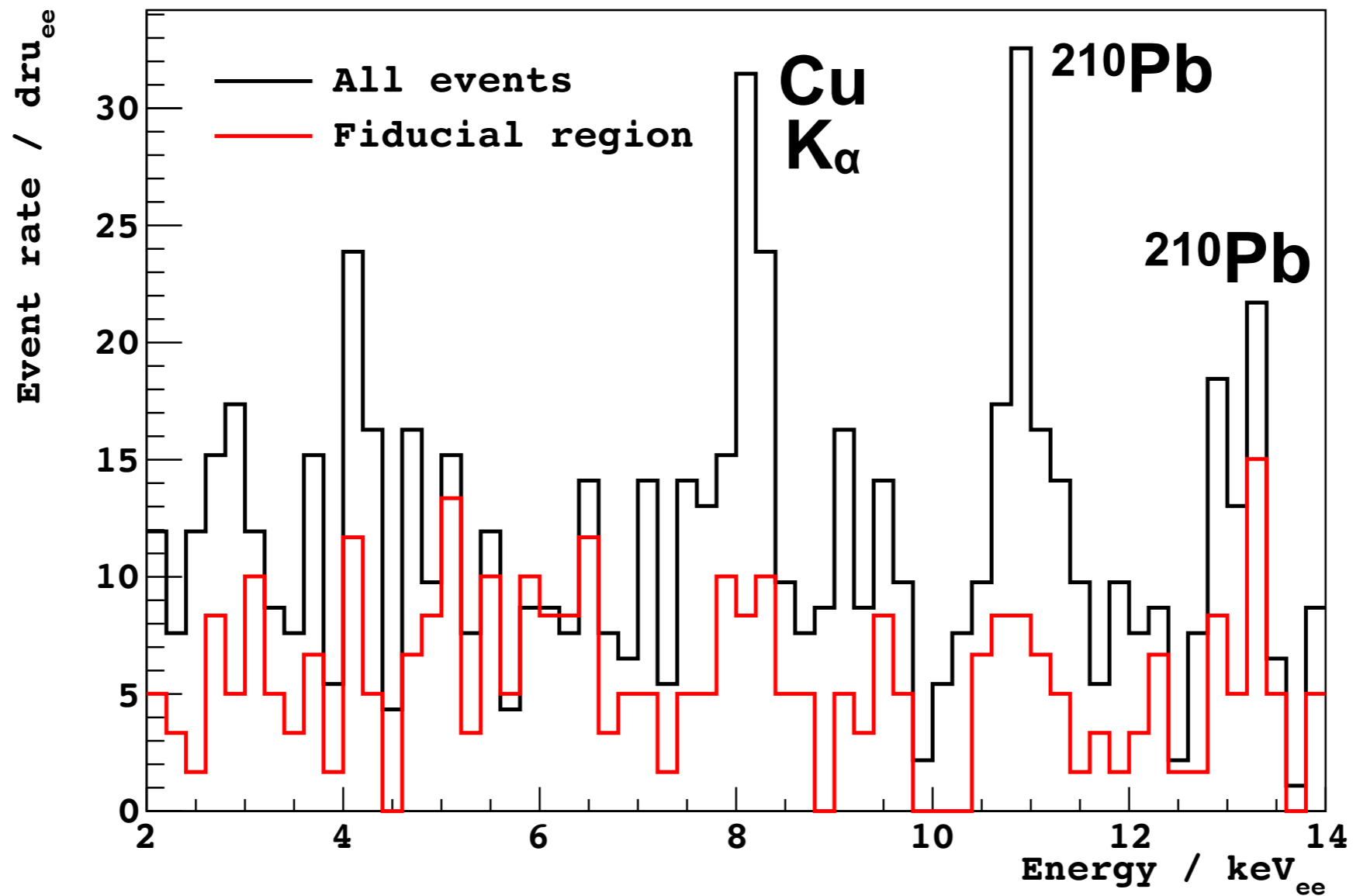

≈ 5 dru in fiducial region, consistent between CCDs
a factor of $\approx 3-4$ lower than our previous background level
 ≈ 2 dru for lead sandwiched CCD

Low energy data

We are analyzing the data from **50 eV to 2 keV**, which provide most sensitivity to low mass WIMPs. Some examples of candidates:

Two example events (data + fit)

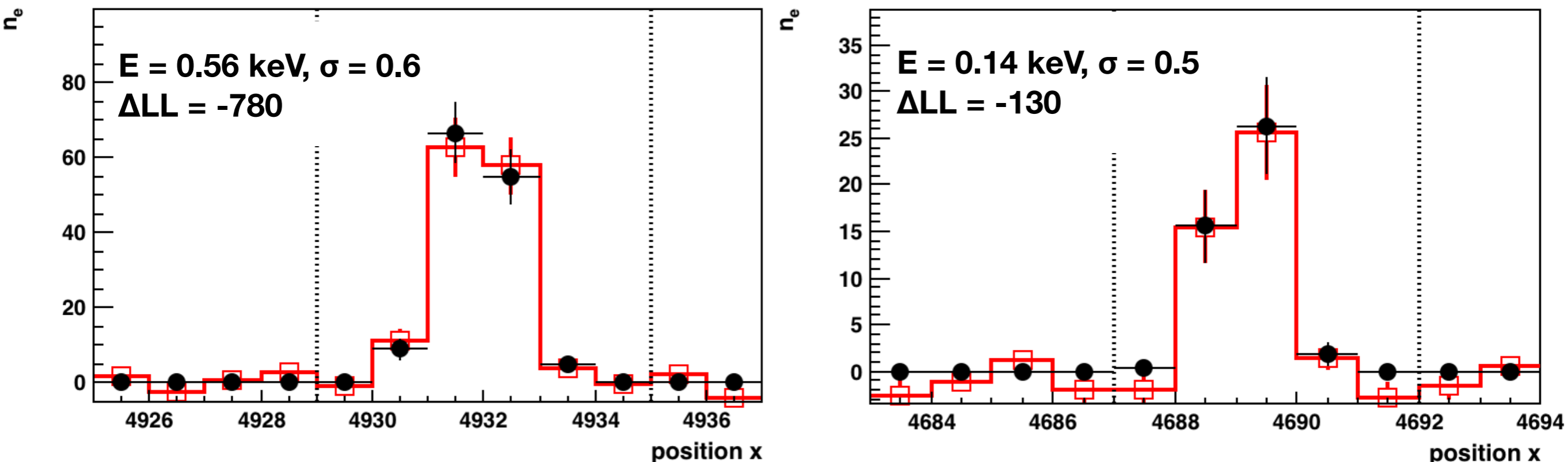

Note: CDMS II silicon potential signal obtained with a $7 \text{ keV}_{\text{nr}}$ threshold ($\approx 2 \text{ keV}_{\text{ee}}$). We are exploring for the first time the silicon target with a much lower threshold of $0.6 \text{ keV}_{\text{nr}}$ ($\approx 0.05 \text{ keV}_{\text{ee}}$).

Sensitivity

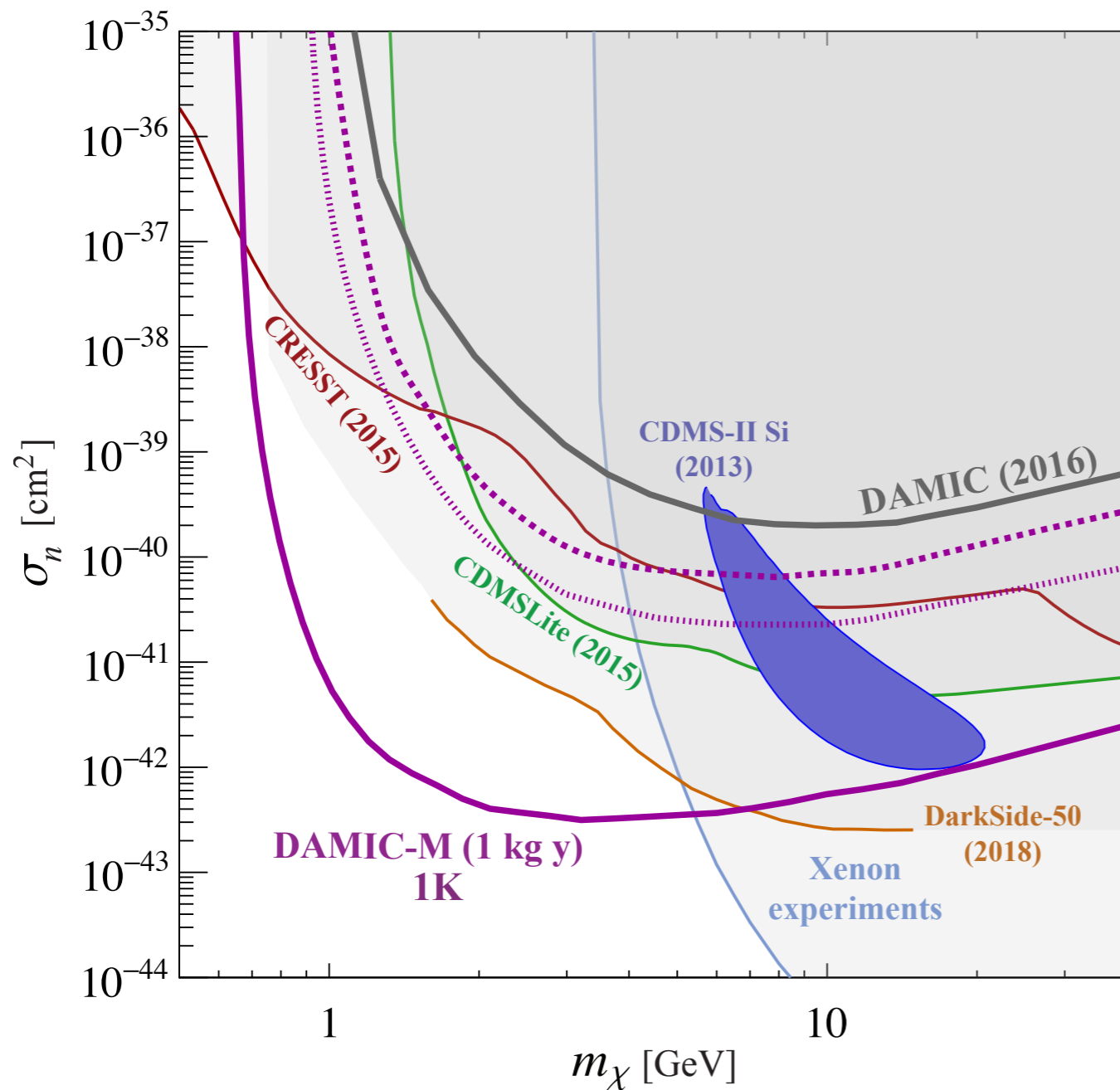

**Current exposure (03/2018)
and bkg (5 keV_{ee}/kg/d)**

**DAMIC (4.6 kg d)
DAMIC (13 kg d)**

**Exposure by
end 2018**

**Three excess events in
CDMS-II Si
0.19% probability for
background-only hypothesis**

PRL111 251301

Background studies

- Cosmogenic ^{32}Si**

Search for spatially correlated beta decays. Sensitivity with current data is few Bq/kg.

Previous results: JINST 10 P08014 (2015)

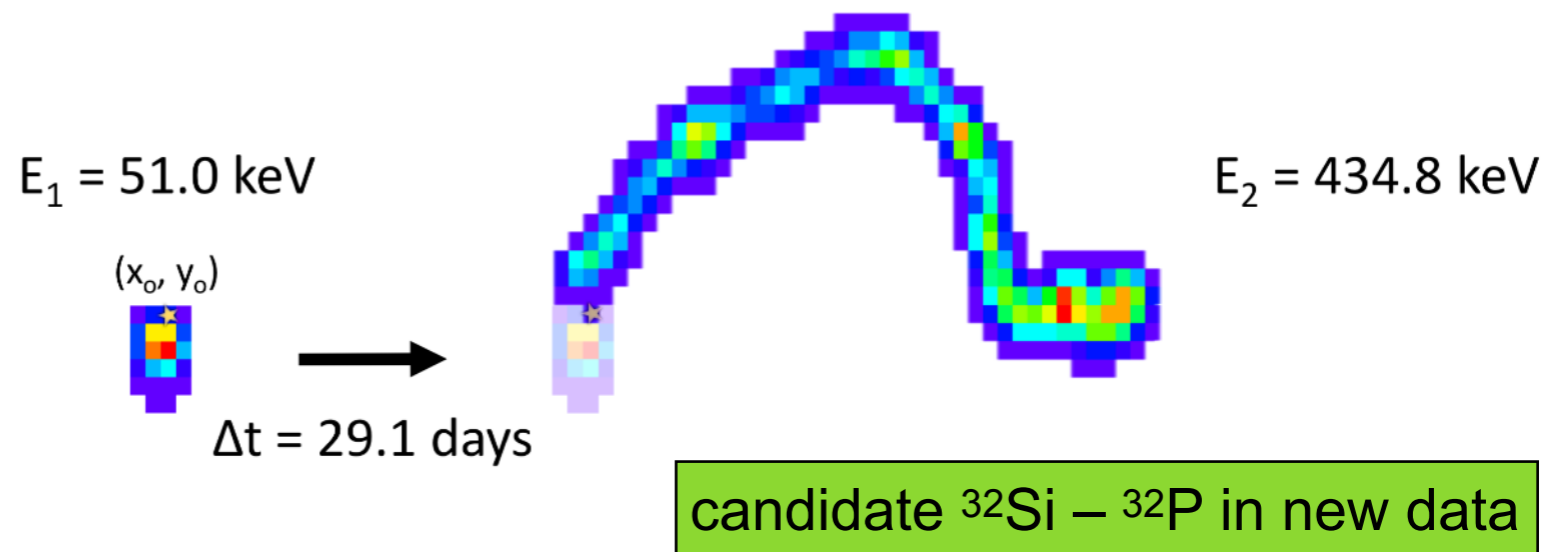
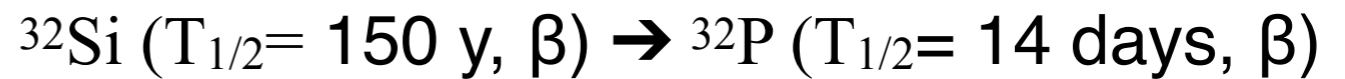

- Bulk and surface background**

ppt levels sensitivity to U+Th bulk contamination. Will demonstrate that the devices themselves are radiopure for kg-year exposures.

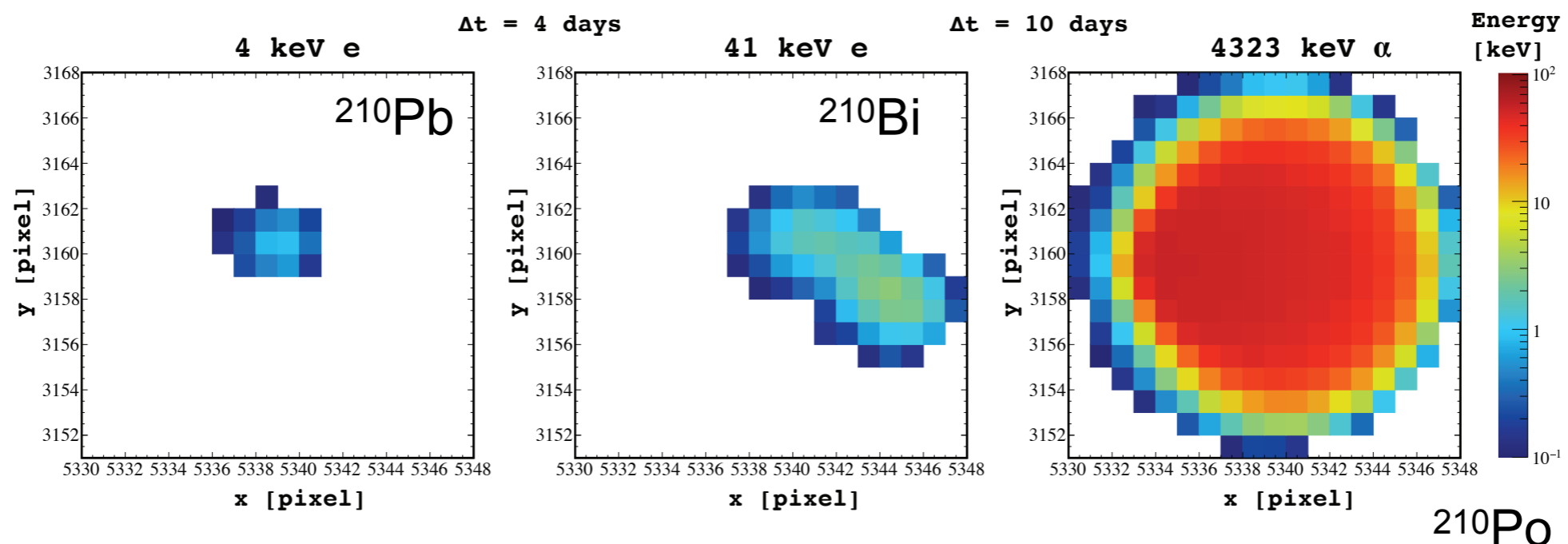

DAMIC-M (1K)

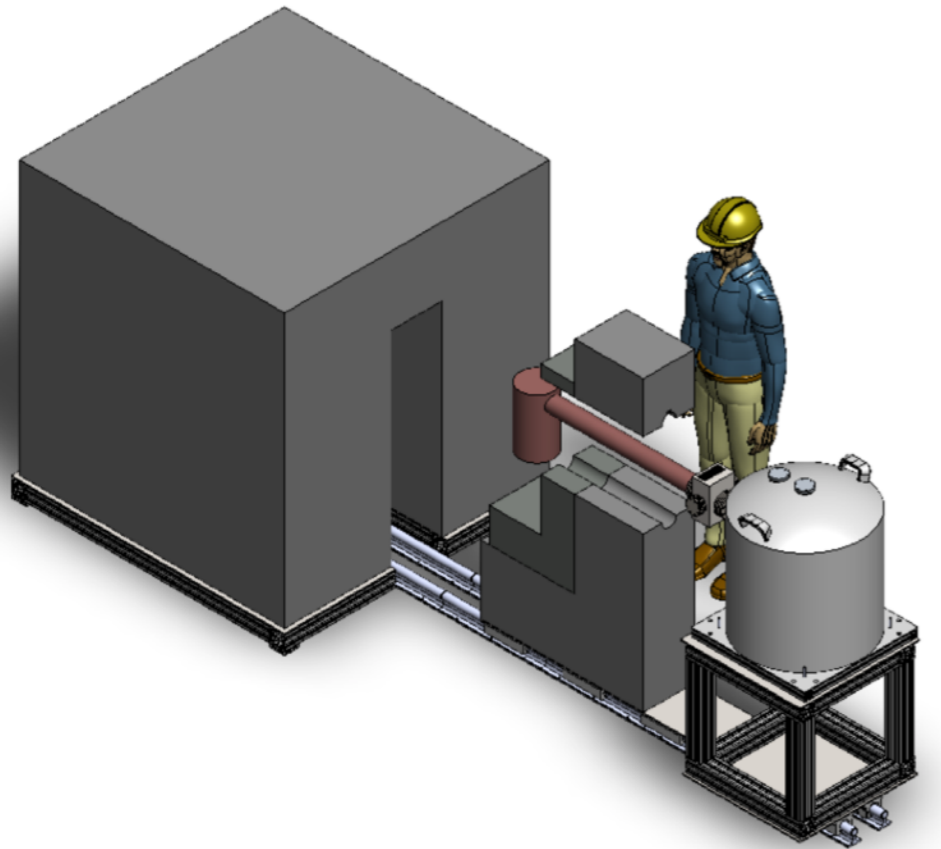

- ▶ **50 CCDs** (1 kg target mass) at LSM (France).
- ▶ Most massive CCDs ever built (**6k x 6k x 1mm, mass 20 g**).
- ▶ Skipper readout for **sub-eV noise**.
- ▶ **Bkg reduction to a fraction of dru** (improved design, materials, procedures).

Institutions:

The University of **Chicago**, University of **Washington**, Pacific Northwest National Laboratory (**PNNL**), **SNOLAB**, Laboratoire de Physique Nucléaire et de Hautes Energies (**LPNHE**), Laboratoire de l'Accélérateur Linéaire (**LAL**), the Laboratoire Souterrain de Modane/Grenoble (**LSM**), University of **Zurich**, **Niels Bohr Institute**, University of **Southern Denmark**, University of **Santander**, Universidad Federal do **Rio de Janeiro**, Centro Atómico **Bariloche**

Large size Skipper CCDs (6k x 4k) for DAMIC-M development (**10 g!**) will arrive at **UW** in Summer 2018.

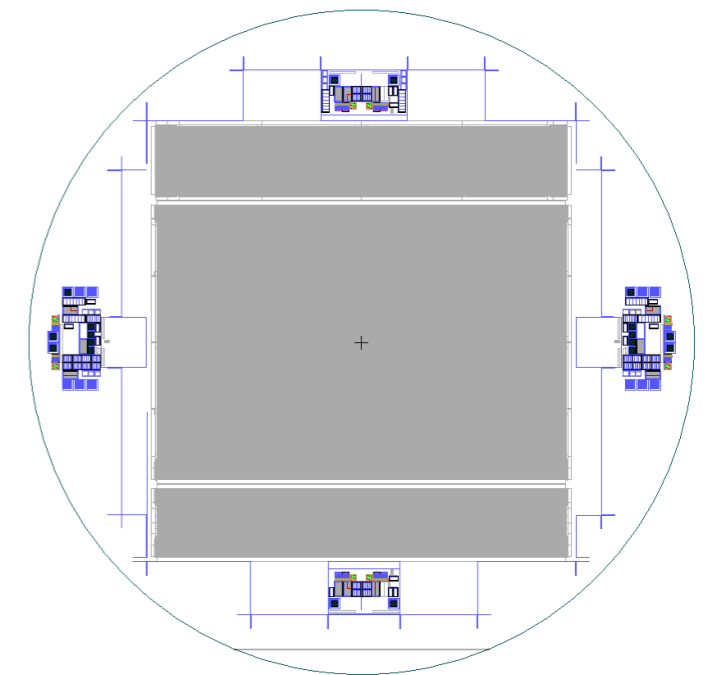

Wafer-layout by S. Holland (LNBL)

Skipper CCD

“Skipper” readout: Perform N uncorrelated measurements of the same pixel.

Effect on low frequency noise

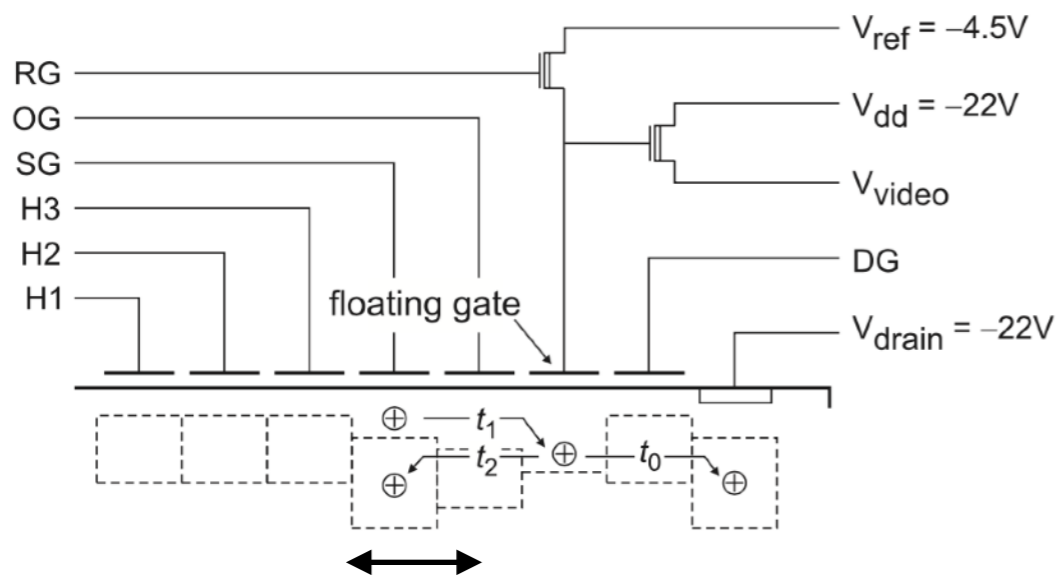

move charge back and forth

Measure ΔV N times

Reference

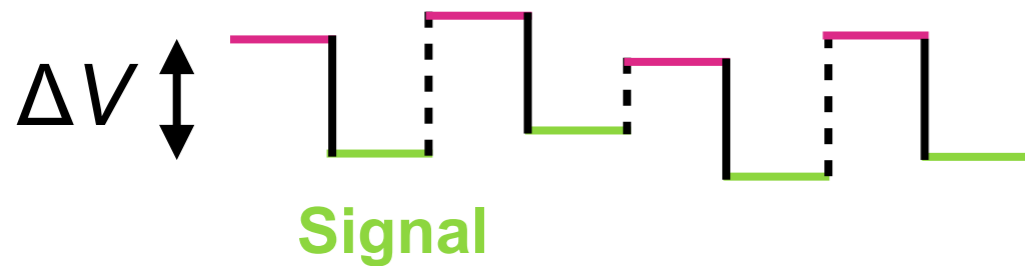

Technology proposed in the 1990s

Conventional readout

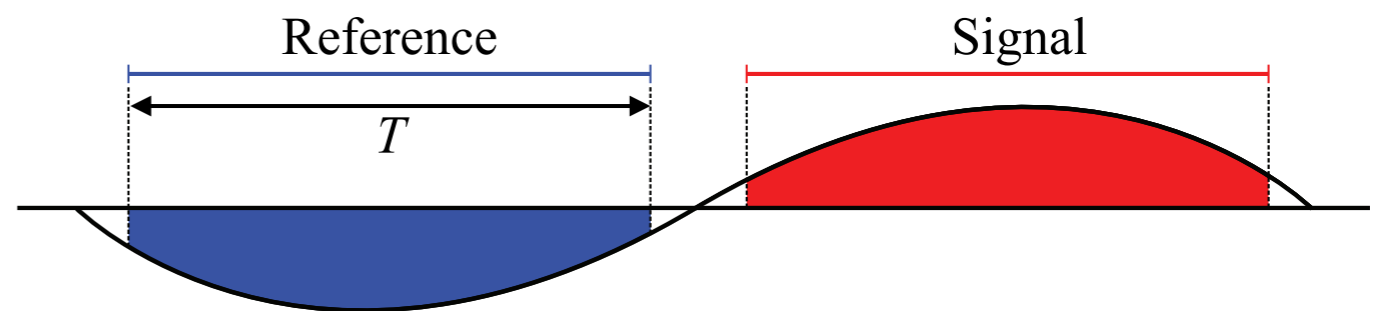

Skipper readout

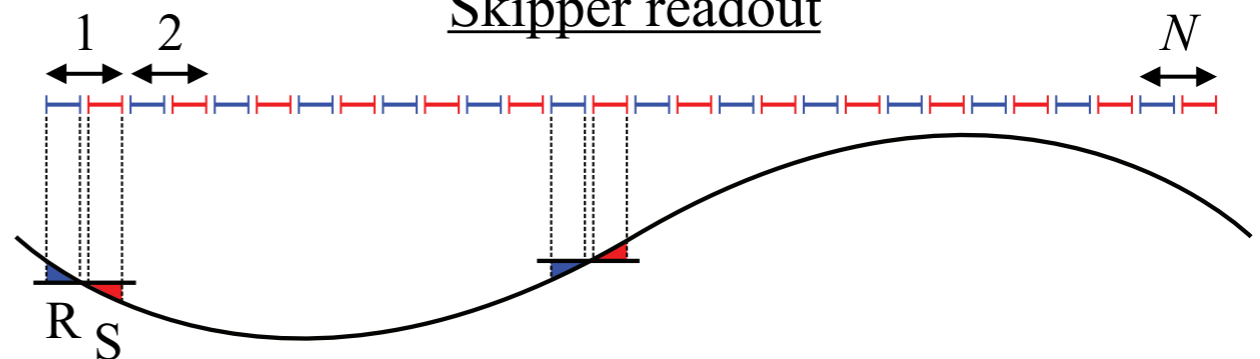

SENSEI

LDRD at Fermilab: Skipper CCDs (**LBNL design**) successfully tested with sub e^- noise. X-ray spectroscopy demonstrated.

Technology will allow 2 e^- (few eV) threshold.

Observed $\sim 1/\sqrt{N}$

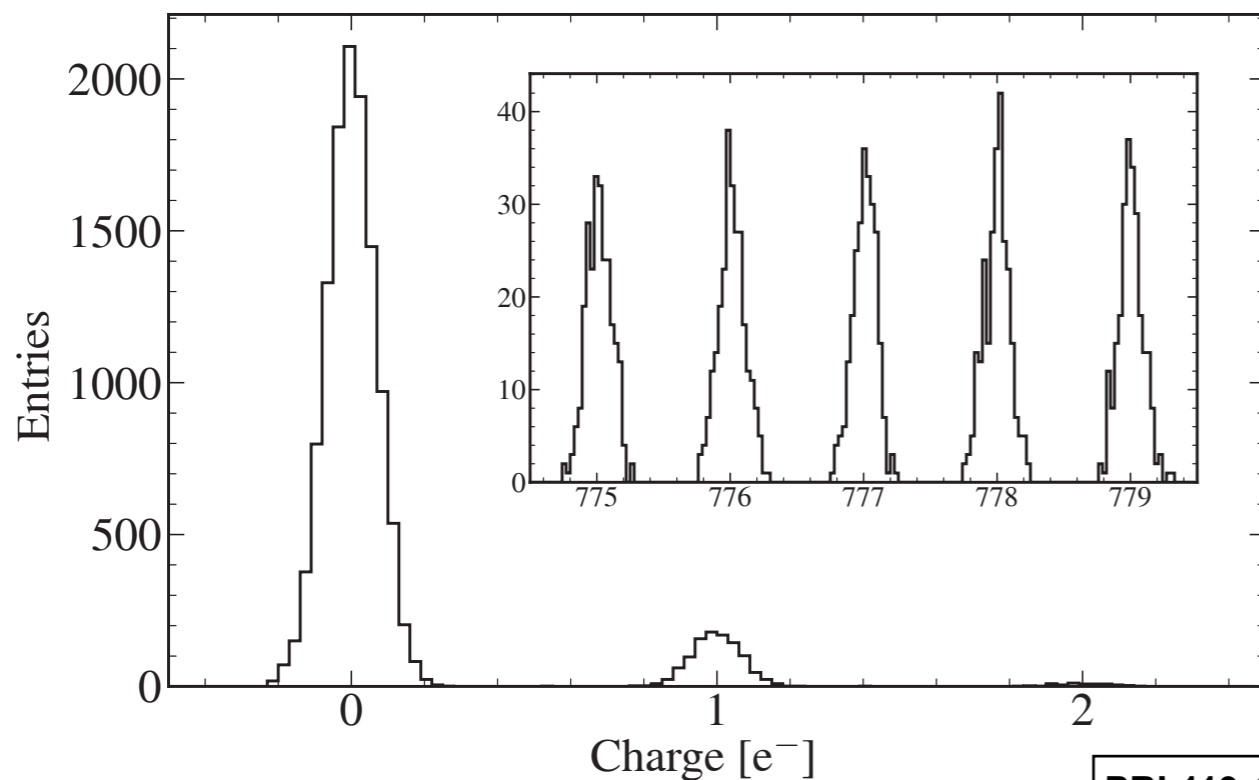

PRL119 131802 (2017)

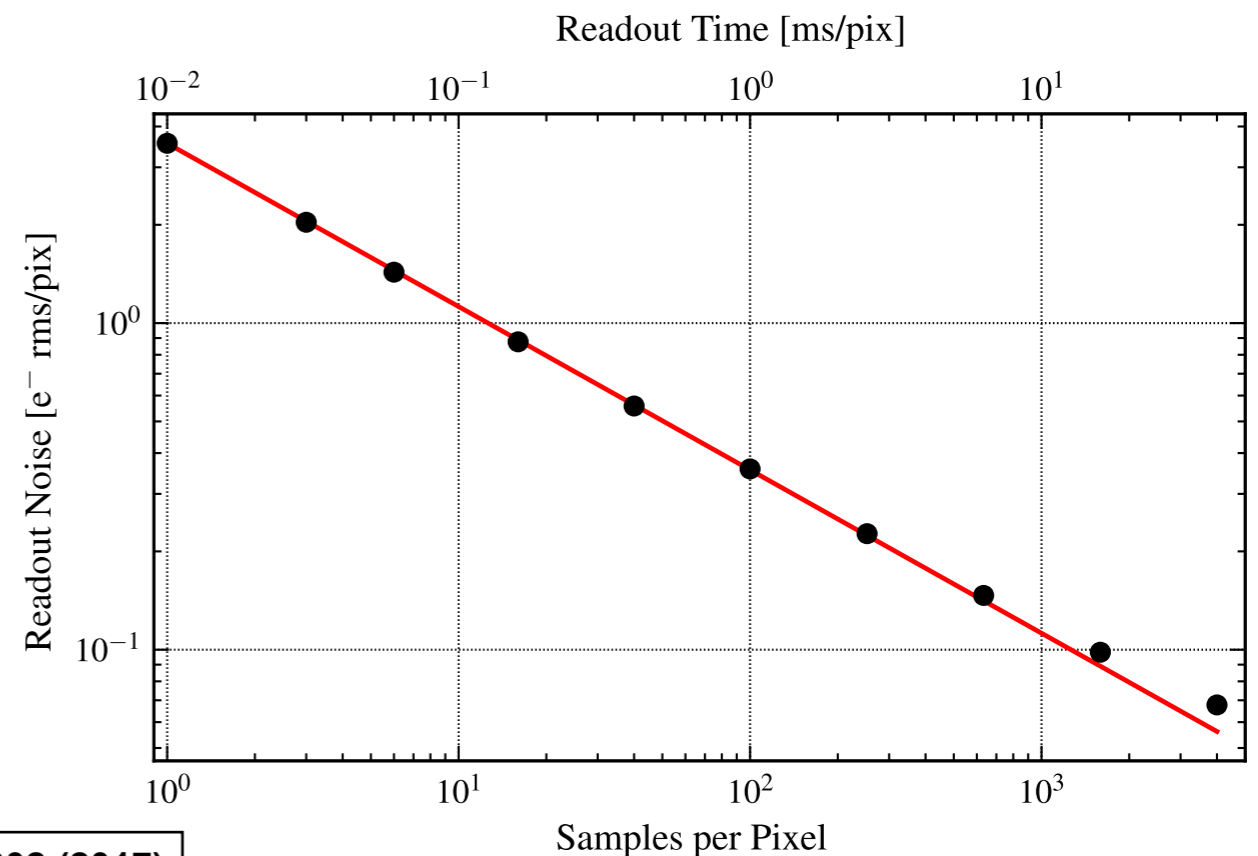

SENSEI limited by dark current: $>10^3$ times higher than DAMIC

Improvements

CCDs: DAMIC-1K CCDs will combine **low dark current** demonstrated by DAMIC at SNOLAB with **skipper readout** tested by SENSEI for devices with few e⁻ threshold for kg-year exposures underground.

Low radioactive background:

- ▶ Goal for DAMIC-M **0.1 dru** (already achieved by MJD and C4, dominated by cosmogenic ³H in bulk silicon).
- ▶ Cryostat by support with PNNL **electroformed copper**.
- ▶ Improved design / operation for background mitigation / tagging.
- ▶ CCD packaging and detector assembly in **radon-free** cleanroom at LSM.
- ▶ Measuring cosmogenic ³H activation in Si at **LANSCÉ** this summer.
- ▶ Store silicon underground + shielded shipping container.

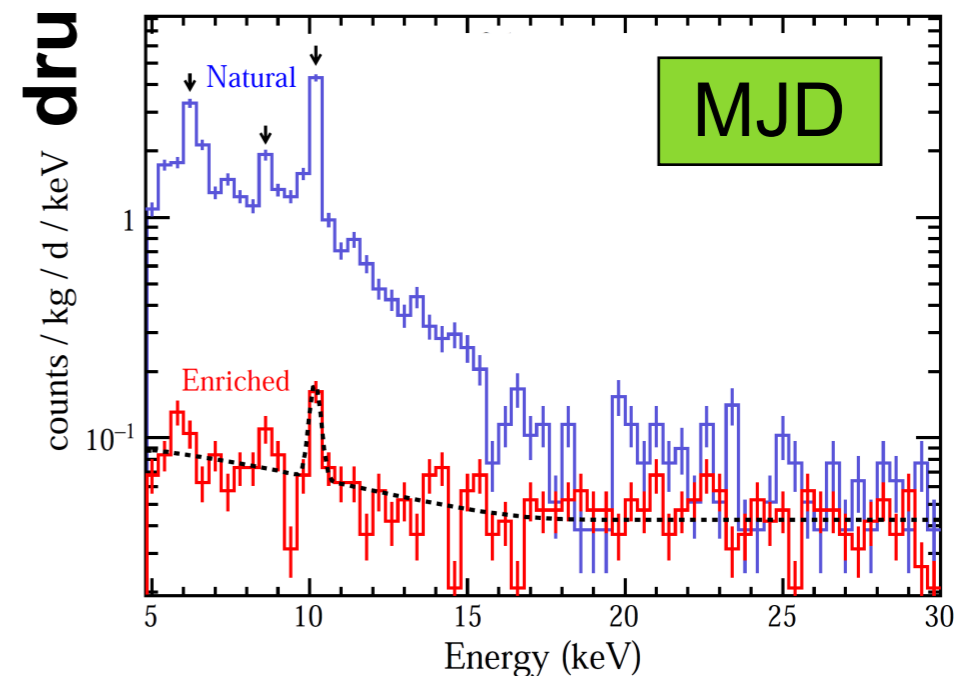

Forecast I

WIMP nuclear recoil search

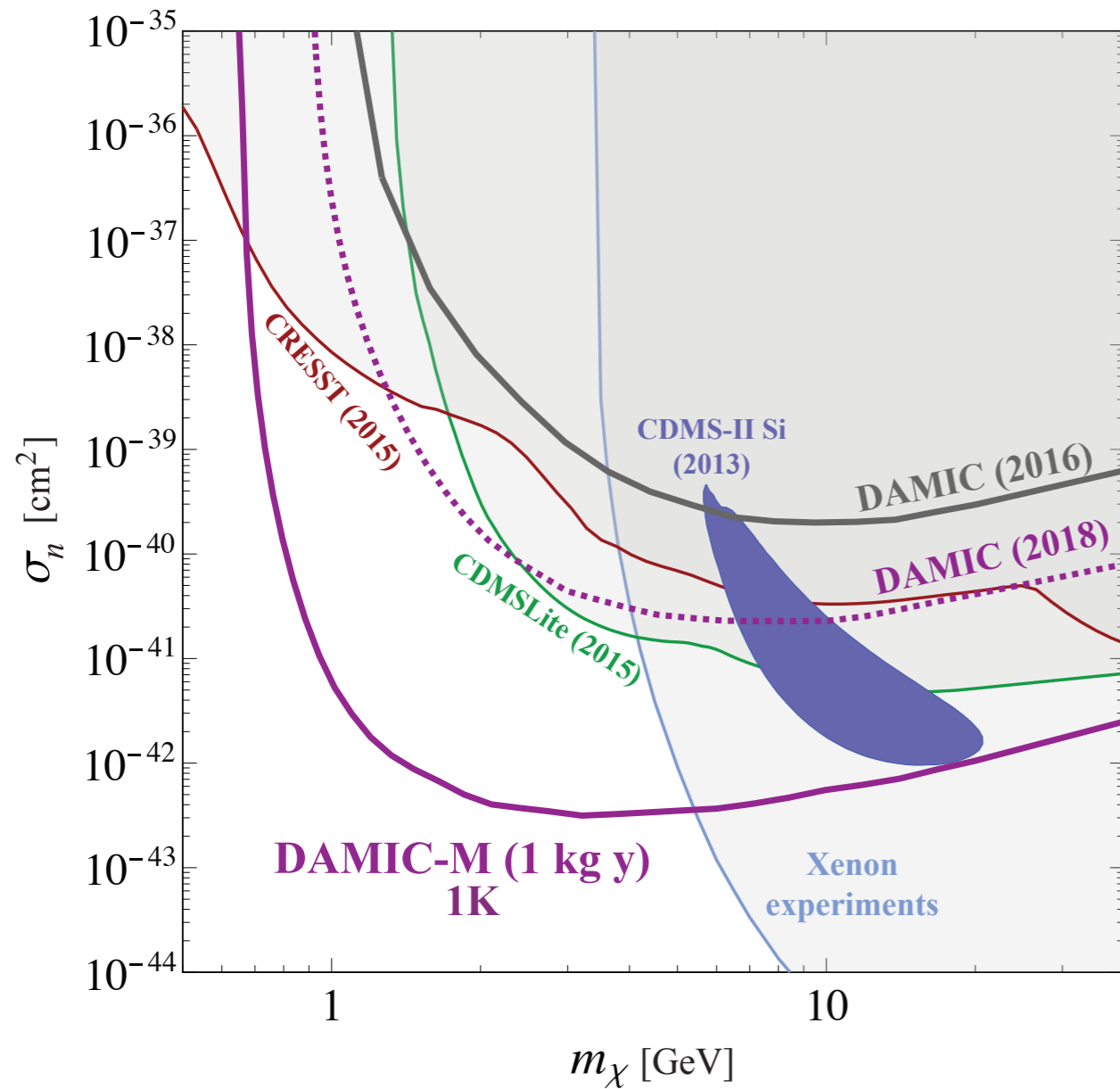

Hidden photon search

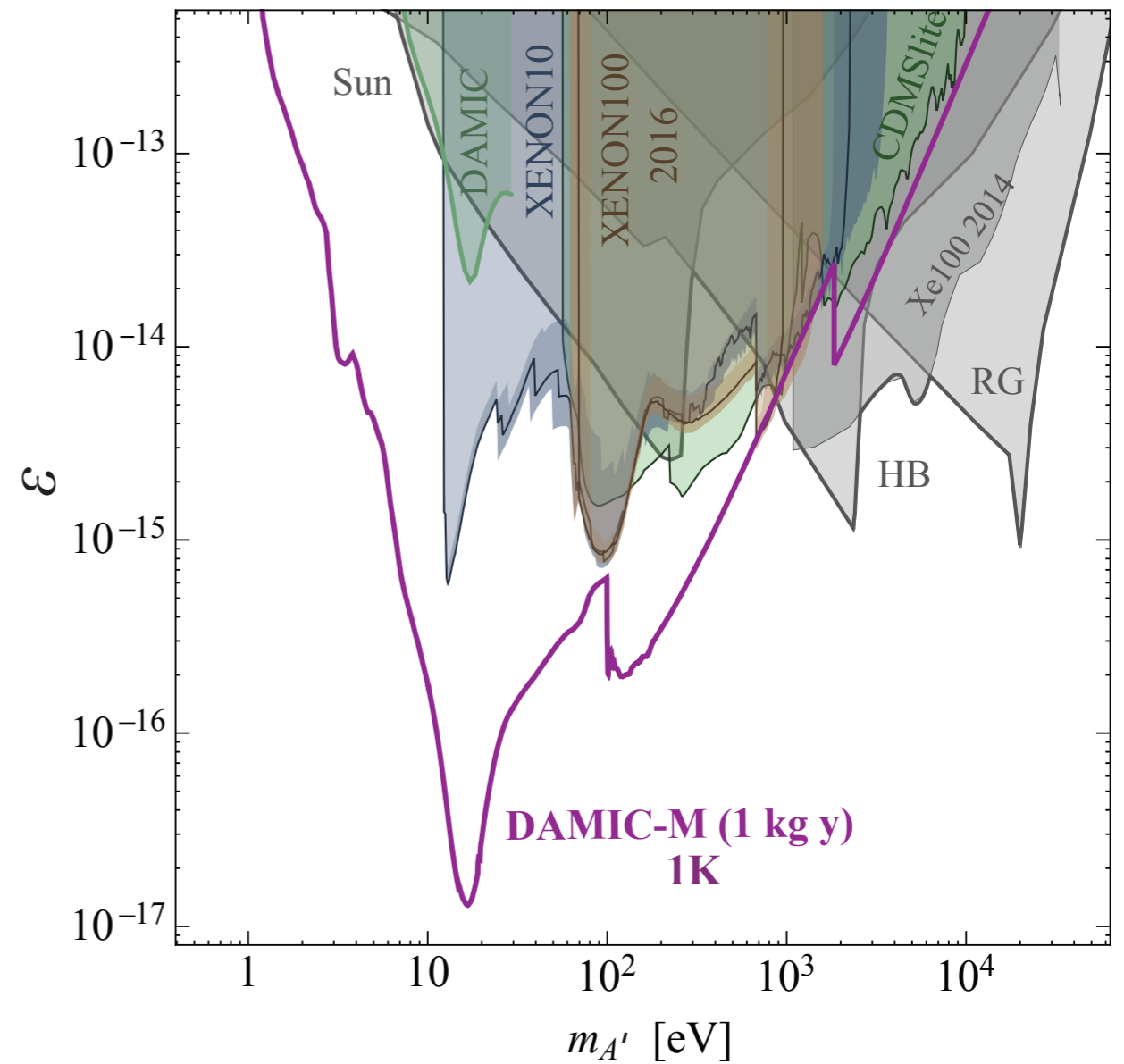

Forecast II

Light dark matter - electron scattering

Heavy mediator

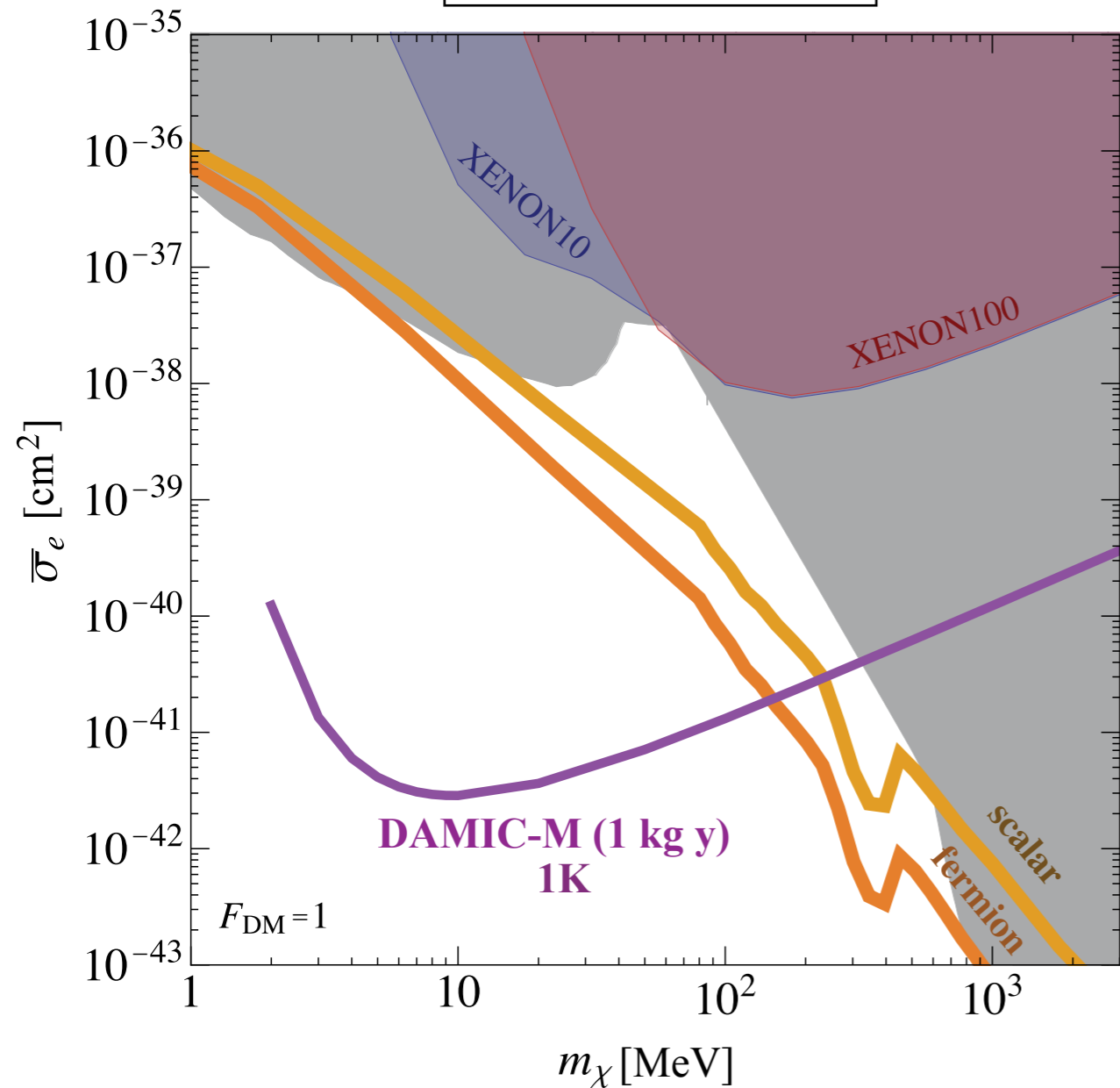

Light mediator

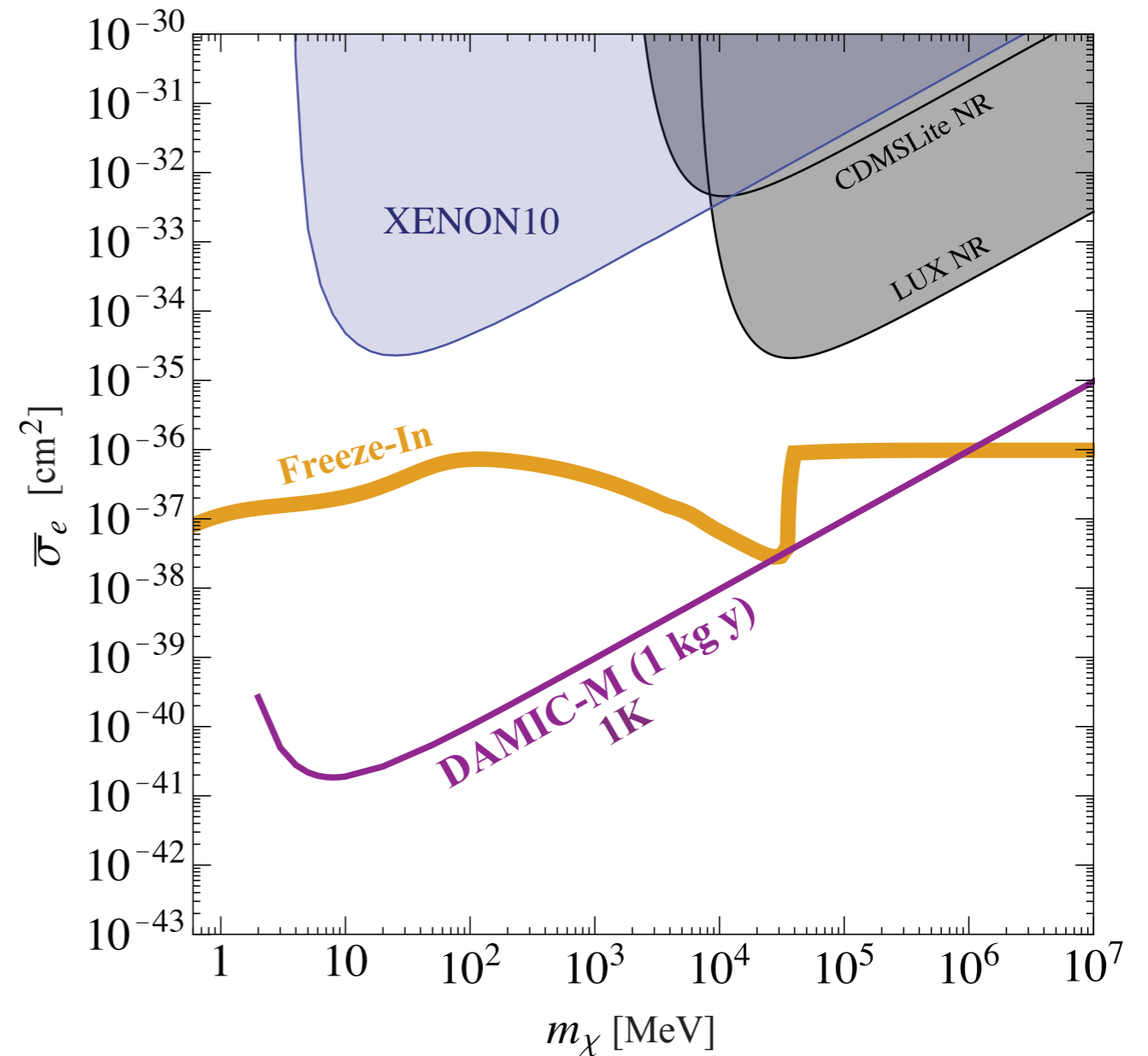

Summary

DAMIC operating with 40g detector since 2017.

Collected DM search exposure:

– 4.6 kg d so far, ~13kg day by the end of 2018.

High quality data with well characterized detector:

- ▶ 50 eV threshold.
- ▶ Low noise (dominated by readout).
- ▶ Few dru background.

These data will provide essential information for the next generation of silicon detectors (DAMIC-M, SuperCDMS):

- ▶ Spectrum below 2 keV.
- ▶ Cosmogenic and radiogenic background in silicon.
- ▶ CCD dark current at lowest temperature.

Next stage: a 1-kg DAMIC detector at LSM in France.

A large skipper CCD will be characterized this year.

SNOLAB setup to continue running.

Thank you!